

The A11VO is a variable displacement pump of axial piston swashplate design for use in open circuit hydrostatic drives.

Designed principally for use in mobile applications.

The pump operates under self-priming condition, with tank pressurisation or with charge pump (impeller).

A wide variety of controls are available.

Setting of the constant power control is possible via external adjustments, even when the unit is operating.

The pump is available with a through drive to accept a gear pump or a second axial piston pump up to the same size (100 % through drive).

SAE mounting flange.

Output flow is proportional to drive speed and pump displacement and is steplessly variable between maximum and zero.



## Ordering Code / Standard Program

### Operating Fluid

Mineral oil (no code)

### Axial piston unit

Variable displacement, swashplate design

A11V

### Charge pump (impeller)

40 60 75 95 130 190 260

without charge pump (no code)

with charge pump

●	●	●	●	●	●	●	
-	-	-	-	●	●	●	L

### Mode of operation

Pump in open circuit

O

### Size

≅ Displacement  $V_{g \max}$  (cm<sup>3</sup>)

40 60 75 95 130 190 260

### Control device

40 60 75 95 130 190 260

				40	60	75	95	130	190	260	
Constant power control	LR			●	●	●	●	●	●	●	LR
with power influence, high pressure related	LR3			●	●	●	●	●	●	●	LR3
with load limiting control hydraulic override, negative	LG1			●	●	●	●	●	●	●	LG1
with load limiting control hydraulic override, positive	LG2			●	●	●	●	●	●	●	LG2
with load limiting control electric override 12V, negative	LE1			○	○	○	●	●	○	○	LE1
with load limiting control electric override 24V, negative	LE2			○	○	○	●	●	○	○	LE2
with pressure cut-off		D		●	●	●	●	●	●	●	L..D
with pressure cut-off, 2 stages		E		●	●	●	●	●	●	●	L..E
with pressure cut-off, remote control			G	●	●	●	●	●	●	●	L..G
with cross sensing control (flow control)			C	●	●	●	●	●	●	●	L..C
with load sensing control			S	●	●	●	●	●	●	●	L..S
with hydr. stroke limiter, neg. control, $\Delta p=25$ bar			H1	●	●	●	●	●	●	●	L..H1
with hydr. stroke limiter, neg. control, $\Delta p=10$ bar			H5	●	●	●	●	●	●	●	L..H5
with hydr. stroke limiter, pos. control, $\Delta p=25$ bar			H2	●	●	●	●	●	●	●	L..H2
with hydr. stroke limiter, pos. control, $\Delta p=10$ bar			H6	●	●	●	●	●	●	●	L..H6
with electrical stroke limiter 12 V			U1	○	●	●	●	●	●	●	L..U1
with electrical stroke limiter 24V			U2	○	●	●	●	●	●	●	L..U2
Constant pressure control	DR			●	●	●	●	●	●	●	DR
remote control			G	●	●	●	●	●	●	●	DRG
for parallel operation			L	○	○	○	●	●	●	●	DRL
load sensing control (flow control)			S	●	●	●	●	●	●	●	DRS
Hydraulic control, pilot pressure related				●	●	●	●	●	●	●	
$\Delta p = 10$ bar	HD1			●	●	●	●	●	●	●	HD1
$\Delta p = 25$ bar	HD2			●	●	●	●	●	●	●	HD2
pressure cut-off		D		●	●	●	●	●	●	●	HD..D
with remote pressure cut-off			G	●	●	●	●	●	●	●	HD..G
Electrical control with proportional solenoid				○	●	●	●	●	●	●	
12 V	EP1			○	●	●	●	●	●	●	EP1
24 V	EP2			○	●	●	●	●	●	●	EP2
pressure cut-off		D		○	●	●	●	●	●	●	EP.D
with remote pressure cut-off			G	○	●	●	●	●	●	●	EP.G

In case of controls with various additional functions take care of the **sequence** of the columns. For each column only 1 option is possible!

● = available

○ = in preparation, available on enquiry

- = not available

**■** = preferred program (preferred types see page 32)

A11V	O	/	1	-	12
------	---	---	---	---	----

Axial piston unit

Charge pump

Mode of operation

Size

Control device

Series

	1
--	---

Index

sizes 40...130	0
sizes 190...260	1

Direction of rotation

viewed on shaft end	clockwise	R
	anti-clockwise	L

Seals

NBR (nitril-caoutchouc), shaft seal in FPM (fluor-caoutchouc)	N
FPM (fluor-caoutchouc)	V

Shaft end

	40	60	75	95	130	190	260	
Splined shaft DIN 5480	●	●	●	●	●	●	●	Z
Parallel with key DIN 6885	●	●	●	●	●	●	●	P
Splined shaft SAE standard for single pump	●	●	●	●	●	●	●	S
standard for combination pump	●	●	●	- <sup>1)</sup>	- <sup>1)</sup>	●	●	T

<sup>1)</sup> Use shaft end S for combination pump

Mounting flange

	40	60	75	95	130	190	260	
SAE 2-hole	●	●	-	-	-	-	-	C
SAE 4-hole	-	-	●	●	●	●	●	D

Service line connections

	40	60	75	95	130	190	260	
Pressure and suction port SAE on (opposite) side, metric mounting threads	●	●	●	●	●	●	●	12

Through drive (assembly possibilities see page 30)

hub	flange	40	60	75	95	130	190	250	
-	-	●	●	●	●	●	●	●	N00
SAE A (N 5/8"-9T 16/32 DP)	SAE A, 2-hole	●	●	●	●	●	●	●	K01
SAE B (N 7/8"-13T 16/32 DP)	SAE B, 2-hole	●	●	●	●	●	●	●	K02
SAE B-B (N 1"-15T 16/32 DP)	SAE B, 2-hole	●	●	●	●	●	●	●	K04
SAE C (N 1 1/4"-14T 12/24 DP)	SAE C, 2-hole	-	●	●	●	●	●	●	K07
SAE C (N 1 1/4"-14T 12/24 DP)	SAE D, 4-hole	-	-	●	●	●	●	●	K86
SAE C-C (N 1 1/2"-17T 12/24 DP)	SAE C, 2-hole	-	-	-	●	●	●	●	K24
SAE D (N 1 3/4"-13T 8/16 DP)	SAE D, 4-hole	-	-	-	-	●	●	●	K17
SAE D (N 1 3/4"-13T 8/16 DP)	SAE E, 4-hole	-	-	-	-	-	●	●	K72
N 30 (DIN 5480)	SAE C, 2-hole	-	●	●	●	●	●	●	K80
N 35 (DIN 5480)	SAE B, 2-hole	●	●	●	●	●	●	●	K79
N 35 (DIN 5480)	SAE C, 2-hole	-	●	●	●	●	●	●	K61
N 40 (DIN 5480)	SAE D, 4-hole	-	-	●	●	●	●	●	K81
N 45 (DIN 5480)	SAE D, 4-hole	-	-	-	●	●	●	●	K82
N 50 (DIN 5480)	SAE D, 4-hole	-	-	-	-	●	●	●	K83
N 50 (DIN 5480)	SAE E, 4-hole	-	-	-	-	-	●	●	K84
N 60 (DIN 5480)	SAE E, 4-hole	-	-	-	-	-	-	●	K67

Swivel angle indicator

Without swivel angle indicator (no code)	●	●	●	●	●	●	●	
Optical swivel angle indicator	○	○	○	●	●	○	○	V
Electronical swivel angle indicator	○	○	●	●	○	○	○	E

## Technical Data

### Fluid

We request that before starting a project detailed information about the choice of pressure fluids and application conditions are taken from our catalogue sheets RE 90220 (mineral oil), RE 90221 (environmentally acceptable hydraulic fluids) and RE 90223 (fire resistant hydraulic fluids, HF).

When using HF- or environmentally acceptable hydraulic fluids possible limitations for the technical data have to be taken into consideration. If necessary please consult our technical department (please indicate type of the hydraulic fluid used for your application on the order sheet). The operation with HFA-, HFB- and HFC- hydraulic fluids requires additional special measures.

### Operating viscosity range

In order to obtain optimum efficiency and service life, we recommend that the operating viscosity (at operating temperature) be selected from within the range:

$$v_{\text{opt}} = \text{operating viscosity } 16 \dots 36 \text{ mm}^2/\text{s}$$

referred to tank temperature (open circuit).

### Viscosity limits

The limiting values for viscosity are as follows:

$$v_{\text{min}} = 5 \text{ mm}^2/\text{s},$$

short term at a max. permissible temp. of  $t_{\text{max}} = 115^\circ\text{C}$

$$v_{\text{max}} = 1600 \text{ mm}^2/\text{s}, \text{ short term on cold start } (t_{\text{min}} = -40^\circ\text{C})$$

Please note that the max. fluid temperature is also not exceeded in certain areas (for instance bearing area).

At temperatures of  $-25^\circ\text{C}$  up to  $-40^\circ\text{C}$  special measures may be required for certain installation positions. Please contact us for further information.

### Selection diagram

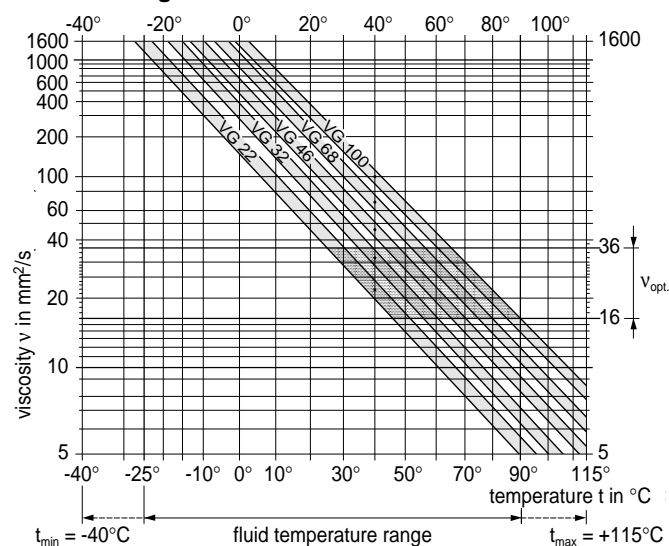

In order to select the correct fluid, it is necessary to know the operating temperature in the tank (open circuit) in relation to the ambient temperature.

The hydraulic fluid should be selected so that within the operating temperature range, the operating viscosity lies within the optimum range ( $v_{\text{opt}}$ ) (see shaded section of the selection diagram). We recommend that the highest possible viscosity range should be chosen in each case.

Example: At an ambient temperature of  $X^\circ\text{C}$  tank temperature is  $60^\circ\text{C}$ . Within the operating viscosity range ( $v_{\text{opt}}$ ; shaded area), this corresponds to viscosity ranges VG 46 or VG 68. VG 68 should be selected.

**Important:** The leakage oil (case drain oil) temperature is influenced by pressure and pump speed and is always higher than the tank temperature. However, at no point in the circuit may the temperature exceed  $115^\circ\text{C}$ .

If it is not possible to comply with the above conditions because of extreme operating parameters or high ambient temperatures please consult us.

### Filtration

The finer the filtration the better the achieved purity grade of the pressure fluid and the longer the life of the axial piston unit. To ensure the functioning of the axial piston unit a minimum purity grade of:

9 to NAS 15, 38

6 to SAE

18/15 to ISO/DIS 4406 is necessary.

In this case we recommend, depending on system and application filter element  $\beta_{20} \geq 100$  for the A11VO.

With the rising differential pressure at the filter element the  $\beta$ -value must not decrease.

At very high temperatures of the hydraulic fluid ( $90^\circ\text{C}$  to max.  $115^\circ\text{C}$ ) at least cleanliness class

8 to NAS 1638

5 to SAE

17/14 to ISO/DIS 4406 is necessary.

If above mentioned grades cannot be maintained please consult us.

### Operating pressure range – inlet

Absolute pressure at port S (suction port)

Design *without* charge pump (impeller)

$p_{\text{abs min}}$  \_\_\_\_\_ 0,8 bar

$p_{\text{abs max}}$  \_\_\_\_\_ 30 bar

Design *with* charge pump (impeller)

$p_{\text{abs min}}$  \_\_\_\_\_ 0,6 bar

$p_{\text{abs max}}$  \_\_\_\_\_ 2 bar

### Operating pressure range – outlet

Pressure at port A or B

Nominal pressure \_\_\_\_\_  $p_N = 350$  bar

Peak pressure \_\_\_\_\_  $p_{\text{max}} = 400$  bar

### Case drain pressure

Permissible case drain pressure at ports  $T_1$  or  $T_2$

$p_L$  \_\_\_\_\_ 2 bar abs.

A leakage line to the tank is necessary.

### Housing flushing

In case of operations with the controls **EP**, **HD**, **DR** or with stroke limiters (**H**, **U**) over a longer period ( $t > 10$  min) under zero flow conditions or operation pressures  $< 15$  bar a flushing is necessary through one of the ports "T1", "T2" or "R" in order to avoid heating of the oil.

Size	40	60	75	95	130	190	260
$q_{V \text{ flushing}}$ (L/min)	2	3	3	4	4	5	6

(Housing flushing is not necessary for design with impeller)

## Technical Data

**Table of values** (theoretical values, without considering  $\eta_{mh}$  and  $\eta_v$ ; values rounded)

Size		40	60	75	95	130	190	260	
Displacement	$V_{g\ max}$ cm <sup>3</sup>	42	58,3	74	93,8	130	192,7	260	
	$V_{g\ min}$ cm <sup>3</sup>	0	0	0	0	0	0	0	
Max. speed <sup>1)</sup> at $V_{g\ max}$	$n_{max\ 1}$ rpm	3000	2700	2550	2350	2100	2100	1800	
Max. perm. speed (speed limit) with increased inlet pressure $p_{abs}$ at suction port S or at $V_g \leq V_{g\ max}$ ( $q_v \leq q_{v\ max\ 1}$ ) (see diagram below)	$n_{max\ perm.}$ rpm	3500	3250	3000	2780	2500	2500	2300	
Max. flow <sup>2)</sup> at $n_{max\ 1}$ ( $V_{g\ max}$ )	$q_{V\ max\ 1}$ L/min	122	153	183	214	265	393	454	
Max. power at $q_{V\ max\ 1}$ ( $\Delta p = 350$ bar)	$P_{max\ 1}$ kW	71	92	110	129	159	236	273	
Permissible torque at $V_{g\ max}$	continuous duty ( $\Delta p = 350$ bar)	$T_N$ Nm	234	324	412	522	723	1073	1447
	max. perm. intermittent ( $\Delta p = 400$ bar)	$T_{max}$ Nm	267	370	471	597	826	1225	1654
Moment of inertia about drive axis	$J$ kgm <sup>2</sup>	0,0048	0,0082	0,0115	0,0173	0,0318		0,0878	
Weight (approx.)	$m$ kg	28	36	45	53	66		125	

**Table of values A11VLO with charge pump (impeller)** (theoretical values, without considering  $\eta_{mh}$  and  $\eta_v$ ; values rounded)

Size		130	200	260
Displacement	$V_{g\ max}$ cm <sup>3</sup>	130	192,7	260
	$V_{g\ min}$ cm <sup>3</sup>	0	0	0
Max. speed <sup>3)</sup> at $V_{g\ max}$	$n_{max\ 1}$ rpm	2500	2500	2300
Max. flow <sup>2)</sup> at $n_{max\ 1}$ ( $V_{g\ max}$ )	$q_{V\ max\ 1}$ L/min	315	467	580
Max. power at $q_{V\ max\ 1}$ ( $\Delta p = 350$ bar)	$P_{max\ 1}$ kW	190	281	349
Moment of inertia about drive axis	$J$ kgm <sup>2</sup>	0,0337		
Weight (approx.)	$m$ kg	69		130

<sup>1)</sup> The values shown are valid for an absolute pressure ( $p_{abs}$ ) of 1 bar at the suction inlet S and when operated on mineral oil.

<sup>2)</sup> 3 % volumetric loss included

<sup>3)</sup> The values shown are valid for an absolute pressure ( $p_{abs}$ ) of at least 0,8 bar and when operated on mineral oil.

### Max. perm. speed (speed limit)

Max. perm. speed (speed limit) with increased inlet pressure  $p_{abs}$  at suction port S or at  $V_g \leq V_{g\ max}$

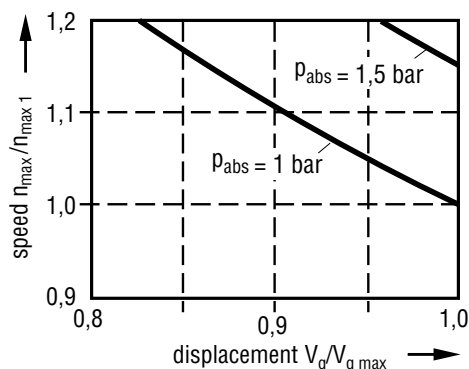

### Mounting position

With the drive shaft to horizontal position; alternative mounting positions are possible, please consult us.

The pump housing must be filled with fluid during commissioning and during normal operation.

For extensive information on the installation position, please read our data sheet RE 90270.

### Calculation of size

$$\text{Output flow } q_v = \frac{V_g \cdot n \cdot \eta_v}{1000} \quad \text{in L/min}$$

$$\text{Drive torque } T = \frac{V_g \cdot \Delta p}{20 \cdot \pi \cdot \eta_{mh}} = \frac{1,59 \cdot V_g \cdot \Delta p}{100 \cdot \eta_{mh}} \quad \text{in Nm}$$

$$\text{Drive power } P = \frac{2\pi \cdot T \cdot n}{60000} = \frac{T \cdot n}{9549} = \frac{q_v \cdot \Delta p}{600 \cdot \eta_t} \quad \text{in kW}$$

$$V_g = \text{geom. displacement per rev.} \quad \text{in cm}^3$$

$$\Delta p = \text{differential pressure} \quad \text{in bar}$$

$$n = \text{speed} \quad \text{in rpm}$$

$$\eta_v = \text{volumetric efficiency}$$

$$\eta_{mh} = \text{mech-hyd. efficiency}$$

$$\eta_t = \text{overall efficiency } (\eta_t = \eta_v \cdot \eta_{mh})$$

## DR Constant Pressure Control

The constant pressure control maintains the pressure in a hydraulic system constant within its control range in spite of changing pump flow requirements. The variable pump supplies only the volume of fluid required by the consumer. Should operating pressure exceed the set pressure, the pump is automatically swivelled back to a smaller angle and the deviation in control corrected.

In unoperated (zero pressure) condition, the pump is swivelled to its starting position ( $V_{g\ max}$ ) by means of a control spring.

Setting range from 50 to 350 bar

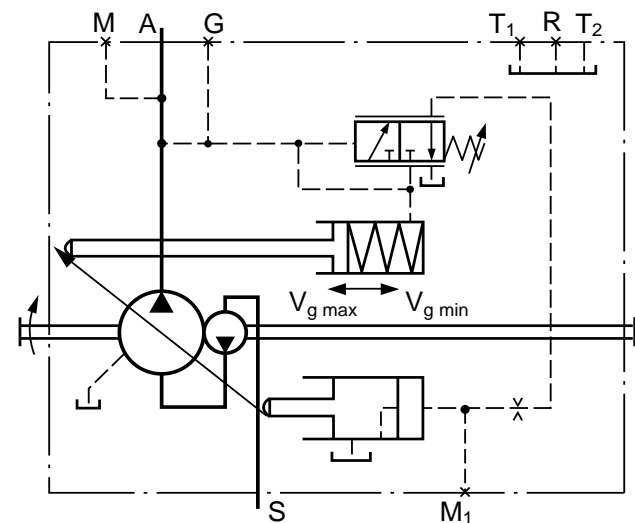
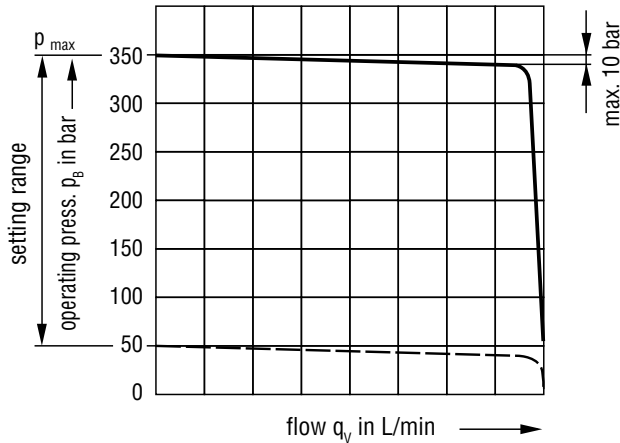

**Constant pressure control DR (integral valve) fixed setting; with charge pump (impeller)**

Any relief valve included in a circuit to limit the max. pressure must be set to a cracking pressure at least 20 bar above the pressure control setting.

### Variation: Load sensing control (DRS)

The load sensing valve is a flow control valve which operates as a function of the load pressure to regulate the pump displacement in order to match the requirement of the consumer unit.

The pump flow is influenced by the external orifice (control block, throttle) fitted between pump and serviced unit, but is not affected by load pressure throughout the range below the set pressure.

The valve compares pressure before and after the orifice and maintains the pressure drop (differential pressure  $\Delta p$ ) across the orifice – and therefore the pump flow – constant.

If differential pressure  $\Delta p$  increases, the pump is swivelled back towards  $V_{g\ min}$ , and if  $\Delta p$  decreases the pump is swivelled out towards  $V_{g\ max}$  until a balance is restored within the valve.

$$\Delta p_{\text{orifice}} = p_{\text{pump}} - p_{\text{serviced unit}}$$

$\Delta p$  may be set within the range 14 bar to 25 bar.

The standard setting is 18 bar. (Please state required setting in clear text).

The standby pressure for zero stroke operation (orifice closed) is insignificant above the  $\Delta p$  setting.

The constant pressure control is superimposed on the load sensing valve, i.e. the load sensing function operates below the set pressure.

The orifice is not included in the standard supply.

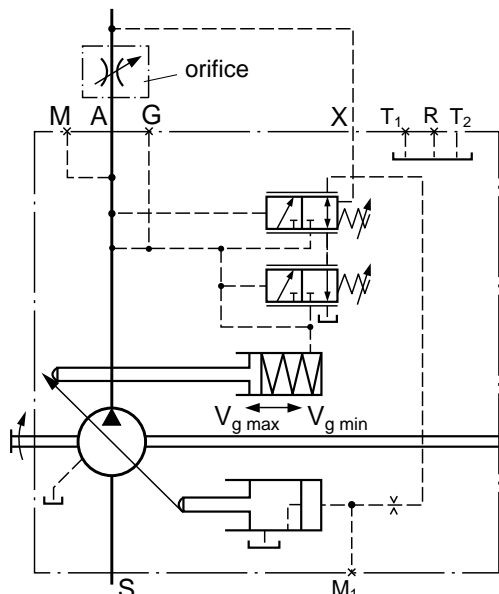
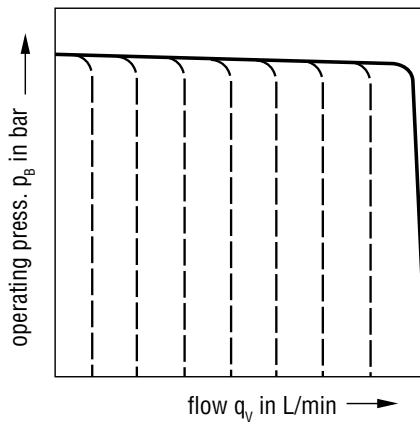

**Constant pressure control with load sensing valve, DRS**

**Variation: Remote constant pressure control (DRG)**

The remote control pressure control can be set by means of a separately mounted pressure relief valve (1) and a lower pressure command value.

Adjustment range from 50 to 350 bar.

Alternatively the system can be started at low operating pressures (stand-by pressure) by actuating a 2/2 control valve (2), also separately mounted.

Both functions can be carried out either singly or in combination (see circuit diagram).

The external valves are *not* included in delivery volume.

For a separate pressure relief valve (1) we recommend:  
 DBDH 6 (manual actuation) see RE 25402

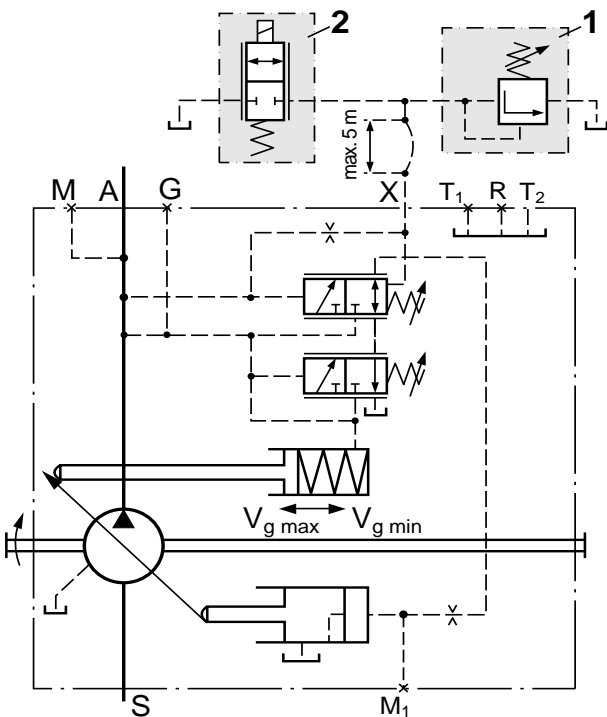
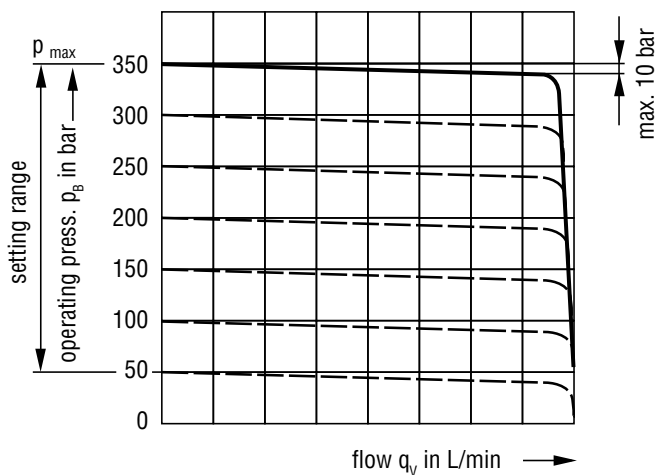

**Remote constant pressure control, DRG**

**Variation: Pressure control for parallel operation (DRL)**

The DRL pressure control is suitable for pressure control of several A11VO axial piston pumps working in parallel.

With an external pressure relief valve (1) the pressure command value for all pumps mounted onto the system can be preset.

Adjustment range from 50 to 350 bar.

Each pump can be disconnected from the system by means of a separately mounted 3/2 control valve (2).

Provision should be made for the check valves (3) in either the delivery line (port A) or the pilot line (port X).

The external valves are *not* included in delivery volume.

For a separate pressure relief valve (1) we recommend:  
 DBDH 6 (manual actuation) see RE 25402

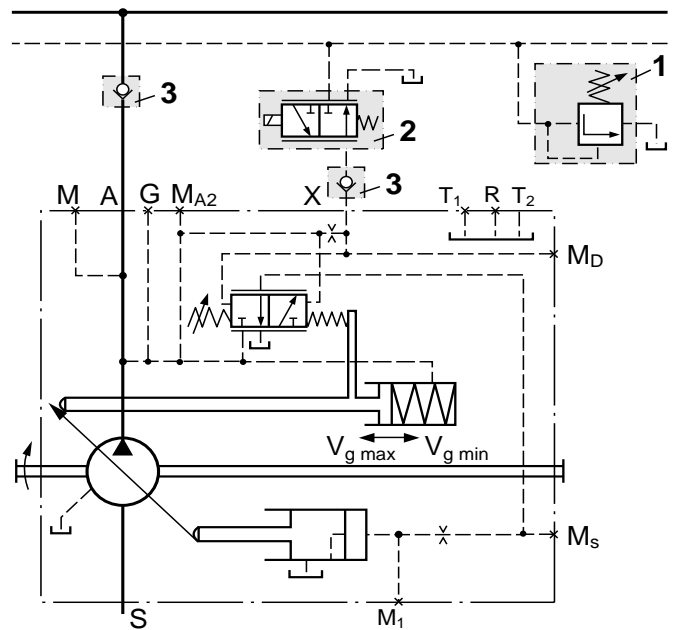

**Pressure control for parallel operation, DRL**

# LR Constant Power Control

The constant power control controls the output volume of the pump in relation to the operating pressure so that, at a constant drive speed, the preset drive power is not exceeded.

$p_B \cdot V_g = \text{constant}$

$p_B =$  operating pressure  
 $V_g =$  displacement

Optimum power usage is obtained by accurately following the power hyperbola.

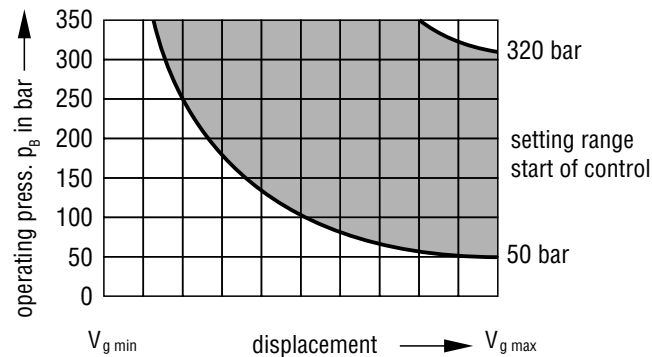

Operating pressure applies a force on a piston within the control piston on to a rocker arm. An externally adjustable spring force is applied to the other side of the rocker arm to determine the power setting.

Should the operating pressure exceed the set spring force, the pilot control valve is operated via the rocker arm, allowing the pump to swivel towards zero output. This in turn reduces the effective moment on the arm of the rocker, thus allowing the operating pressure to rise in the same ratio by which the output flow is reduced ( $p_B \cdot V_g = \text{constant}$ ).

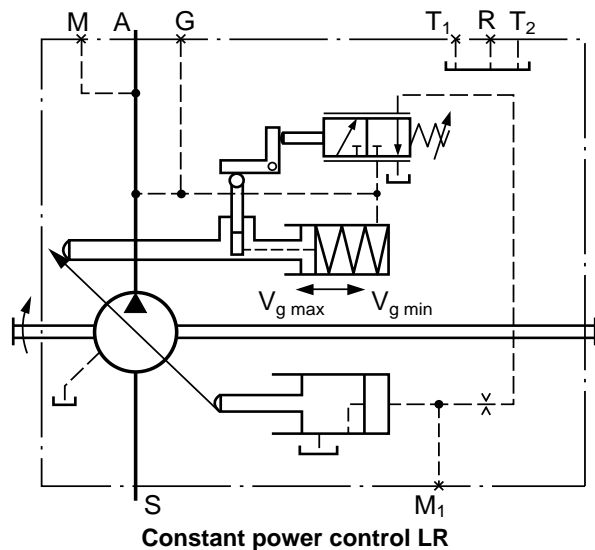

The output power curve is influenced by the efficiency of the pump. When ordering, state in clear text:

- input power P (kW)
- input speed n (rpm)
- max. output flow  $q_{V_{max}}$  (L/min)

After all technical details have been clarified, a power diagram can be produced by computer.

## Variation: Integral pressure cut-off (LRD)

The pressure cut-off is in effect a constant pressure control which swivels the pump back to  $V_{g_{min}}$  when the preset operating pressure is reached.

This function overrides the constant power control, i.e. the constant power control is effective below the preset operating pressure. The valve is integrated into the control housing and is set in the factory to a fixed pressure.

Setting range from 50 to 350 bar

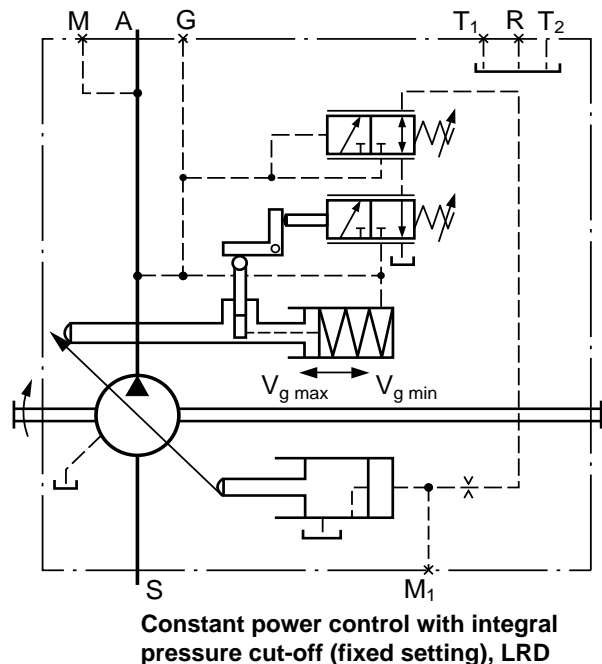
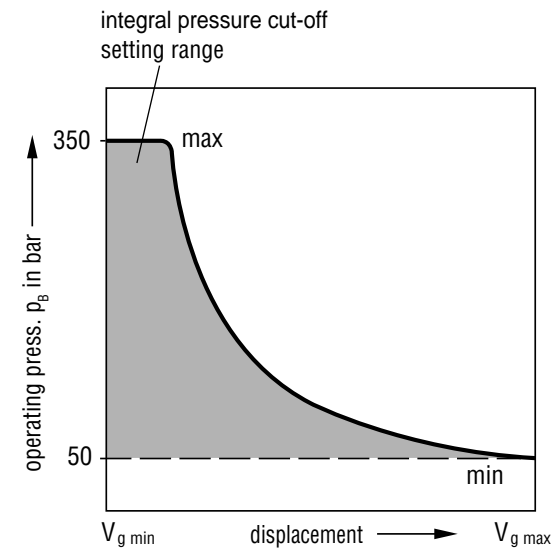



**Variation: Load sensing valve (LRS)**

The load sensing valve is a flow control valve which operates as a function of the load pressure to regulate the pump displacement in order to match the requirement of the consumer unit.

The pump flow is influenced by the external orifice (control block, throttle) fitted between pump and serviced unit, but is not affected by load pressure throughout the range below the power curve.

The valve compares pressure before and after the orifice and maintains the pressure drop (differential pressure  $\Delta p$ ) across the orifice – and therefore the pump flow – constant.

If differential pressure  $\Delta p$  increases, the pump is swivelled back towards  $V_{g \min}$ , and if  $\Delta p$  decreases the pump is swivelled out towards  $V_{g \max}$  until a balance is restored within the valve.

$$\Delta p_{\text{orifice}} = p_{\text{pump}} - p_{\text{serviced unit}}$$

$\Delta p$  may be set within the range 14 bar to 25 bar.

The standard setting is 18 bar. (Please state required setting in clear text).

The standby pressure for zero stroke operation (orifice closed) is insignificant above the  $\Delta p$  setting.

The constant power control and the pressure cut-off are superimposed on the load sensing valve, i.e. the load sensing function operates below the set power hyperbola and set pressure.

The orifice is not included in the standard supply.

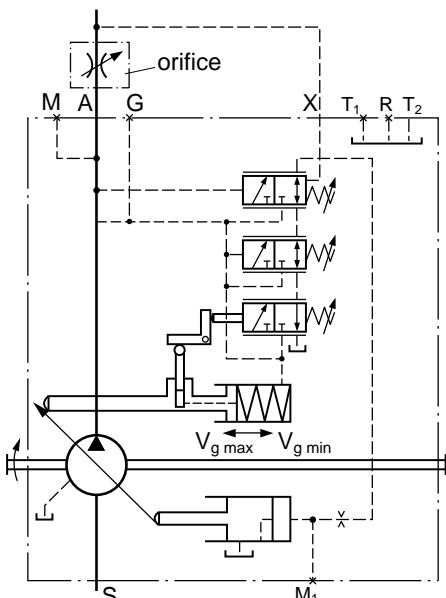
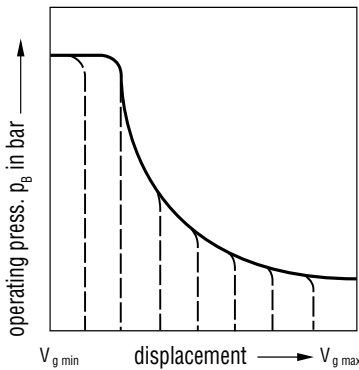

**Constant power control with pressure cut-off and load sensing valve, LRDS**

**Variation: Electrical stroke limiter (LRU1, LRU2)**

The electrical stroke limiter allows the displacement to be infinitely varied or limited as required.

The displacement is set by means of the control current generated by the proportional solenoid.

A 12V DC (U1) or a 24V DC (U2) supply is required for the control of the proportional solenoid.

The electrical stroke limiter is overridden by the constant power control, i.e. below the power curve (power hyperbola), displacement is adjusted in relation to the control current. If the set flow or the operating pressure is such that the power curve is exceeded, the constant power control overrides the stroke limiter and reduces displacement until the power hyperbola is restored.

**LRU1, LRU2 → Function:  $V_{g \min}$  to  $V_{g \max}$  (positive control)**

As the control current increases, the pump swivels to a larger displacement. (Starting position at zero pressure:  $V_{g \max}$ )

At operating pressure > 30 bar the pump swivels from  $V_{g \max}$  to  $V_{g \min}$  (pilot current < start of control).

Start of control at approx.: 400 mA (U1)      200 mA (U2)  
 End of control at approx.: 1200 mA (U1)      600 mA (U2)

Insulation class IP 54, control from  $V_{g \min}$  to  $V_{g \max}$

A pressure of 30 bar is needed for the control. The oil required for this is taken either from the high pressure or from the external adjustment pressure at port G ( $\geq 30$  bar).

If the operating pressure is  $\geq 30$  bar and  $V_{g \min} > 0$  no external control pressure is required and port G should be plugged before commissioning. If port G is not to be used then the parts of the shuttle valve are to be removed from the pump (see note on repair instructions RDE 92500-R).

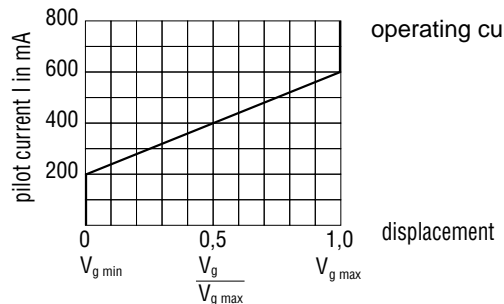

**operating curve LRU2**

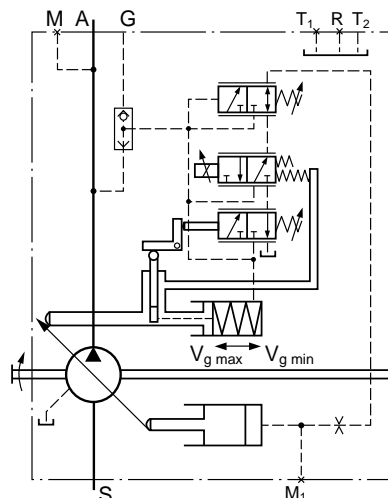

**Constant power control with pressure cut-off and el. stroke limiter, LRU2 (Function:  $V_{g \min}$  to  $V_{g \max}$ )**

The following are used for control of the proportional solenoid:

- Proportional amplifier **PV** \_\_\_\_\_ (see RE 95023)
- Proportional amplifier **VT 2000** \_\_\_\_\_ (see RE 29908)
- Chopper amplifier **CV** \_\_\_\_\_ (see RE 95029)

**Variation: Hydraulic stroke limiter (LRH...)**

The hydraulic stroke limiter allows the maximum displacement to be infinitely varied or limited as required.

Control range  $V_{g \max}$  to  $V_{g \min}$ .

The displacement is set by means of the pilot pressure applied at port Y (max. 40 bar).

The hydraulic stroke limiter is overridden by the constant power control, i.e. below the power curve (power hyperbola), displacement is adjusted in relation to pilot pressure. If the set flow or the operating pressure is such that the power curve is exceeded, the constant power control overrides the stroke limiter and reduces displacement until the power hyperbola is restored.

**H1 bzw. H5 → Function:  $V_{g \max}$  to  $V_{g \min}$  (negative control)**

As pilot pressure increases the pump swivels towards lower displacement.

Starting position at zero pressure:  $V_{g \max}$

Start of control, (at  $V_{g \max}$ ), settable \_\_\_\_\_ 4 – 10 bar

When ordering, please state required start of control in clear text.

**H1 → pilot pressure increase ( $V_{g \max} - V_{g \min}$ ) \_\_\_\_\_  $\Delta p = 25$  bar**

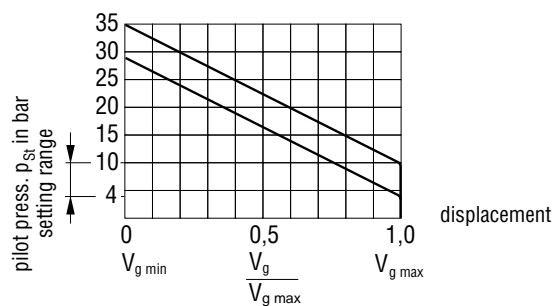

**H5 → pilot pressure increase ( $V_{g \max} - V_{g \min}$ ) \_\_\_\_\_  $\Delta p = 10$  bar**

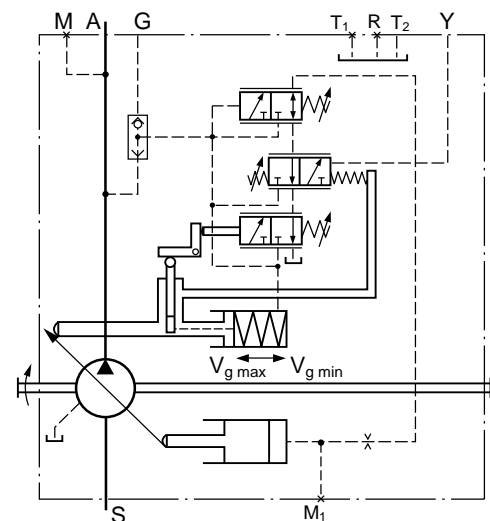
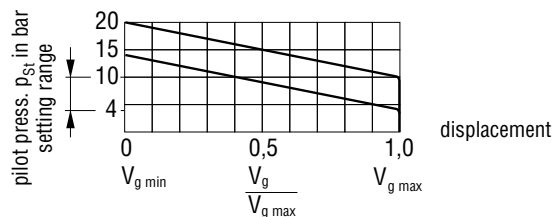

**Constant power control with pressure cut-off and hydraulic stroke limiter, LRDH1, LRDH5 (Function:  $V_{g \max}$  to  $V_{g \min}$ )**

**H2 / H6 → Function:  $V_{g \min}$  to  $V_{g \max}$  (positive control)**

As pilot pressure increases the pump swivels towards higher displacement.

Starting position at zero pressure:  $V_{g \max}$

At operating pressure > 30 bar the pump swivels from  $V_{g \max}$  to  $V_{g \min}$  (pilot pressure < start of control).

Start of control (at  $V_{g \min}$ ), settable \_\_\_\_\_ 4 – 10 bar

When ordering, please state required start of control in clear text.

**H2 → pilot pressure increase ( $V_{g \min} - V_{g \max}$ ) \_\_\_\_\_  $\Delta p = 25$  bar**

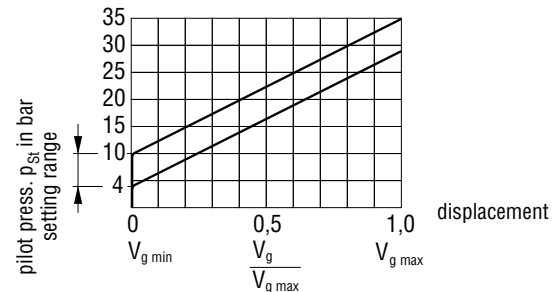

**H6 → pilot pressure increase ( $V_{g \min} - V_{g \max}$ ) \_\_\_\_\_  $\Delta p = 10$  bar**

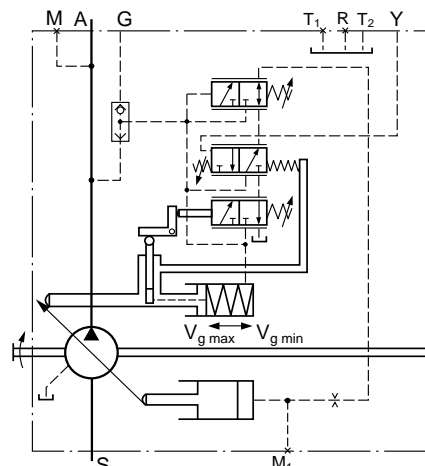
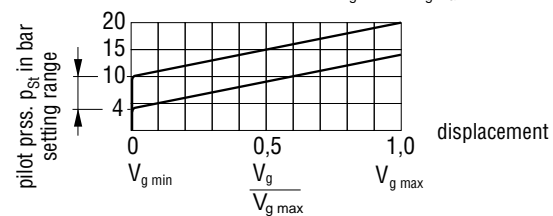

**Constant power control with pressure cut-off and hydr. stroke limiter, LRDH2, LRDH6 (Function:  $V_{g \min}$  to  $V_{g \max}$ )**

A pressure of 30 bar is needed for the control. The oil required for this is taken either from the high pressure or from the external adjustment pressure at port G ( $\geq 30$  bar).

If the operating pressure is  $\geq 30$  bar and  $V_{g \min} > 0$  no external control pressure is required and port G should be plugged before commissioning. If port G is not to be used then the parts of the shuttle valve are to be removed from the pump (see note on repair instructions RDE 92500-R).

## Control of Power Setting

### Variation: Cross sensing control (LRC)

Cross sensing control is a summation power control system, whereby the total power, both of the A11VO and of a pump mounted onto the through drive and also power controlled, are kept constant.

If a pump is operating at pressures below the start of the control curve setting, then the surplus power not required, in a critical case up to 100%, becomes available to the other pump. Total power is thus divided between two systems as required.

Any power being released by means of pressure cut-off or other overload is not taken into account.

### Variation: Power influence, high pressure related (LR3)

Power influence, high pressure related is a summation power control system, whereby the power setting is loaded with the *operating pressure* of a fixed pump mounted onto the system (port Z).

The A11VO can thus be set to 100% of the total power. The power setting of the A11VO will only be reduced if the operating pressure of the constant pump increases dependent on load. The relevant power drop is brought about by adjustment of the piston area.

### Variation: Load limiting control, (LG1, LG2)

In contrast to summation power control, load limiting control works by loading the power control with an external *pilot pressure*. This pilot pressure acts on the adjustment spring of the power regulator via port Z.

The mechanically adjusted basic setting can be varied by means of different pilot pressure settings, enabling different mode settings. If the pilot pressure signal is then varied by means of a power limiting regulator the total hydraulic power is equal to the drive input power. The pilot pressure used for power control is generated by an external control element that is not a component part of the A11VO. (See also data sheet RE 95072, electronic load limiting control for excavators, GLB).

### LG1, load limiting control with negative power control

Load limiting control with negative power control LG1 works by the force resulting from the pilot pressure acting against the adjustment spring of the power regulator, i.e. increasing the pilot pressure reduces the power output.

### LG2, load limiting control with positive power control

Load limiting control with positive power control LG2 works by the force resulting from the pilot pressure supporting the adjustment spring of the power regulator, i.e. an increase in pilot pressure increases the power output.

## Control of power setting

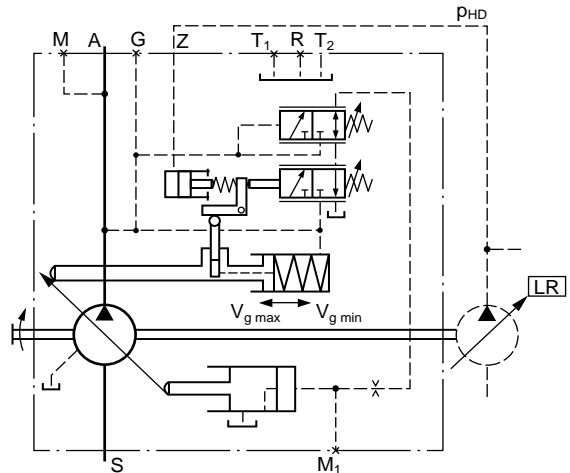
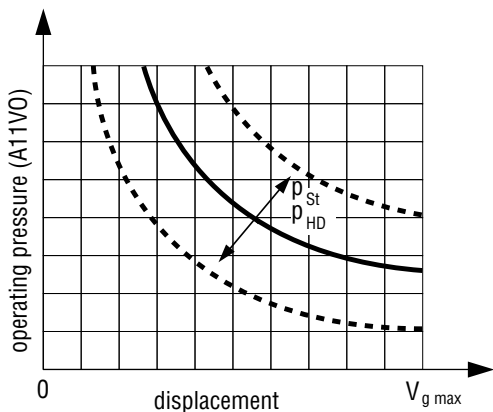

Power control with pressure cut-off and cross sensing control, LRCD

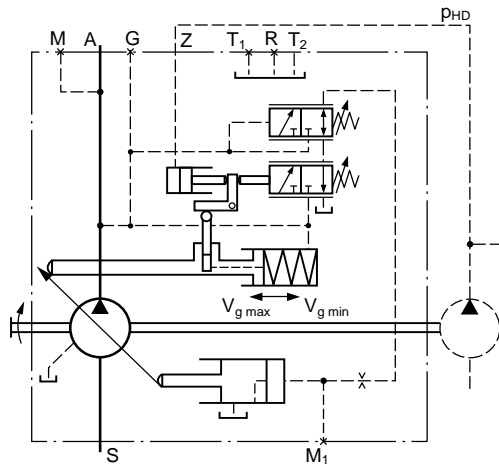

Power influence, high pressure related with pressure cut-off, LR3D

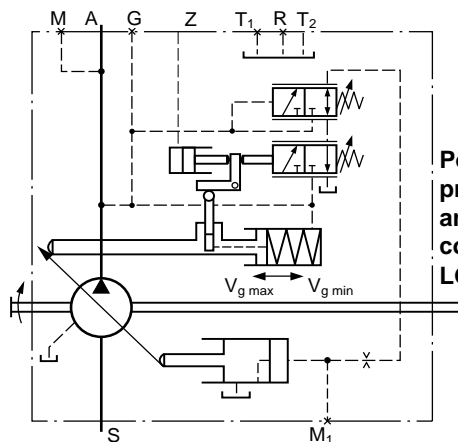

Power control with pressure cut-off and load limiting control, negative, LG1D

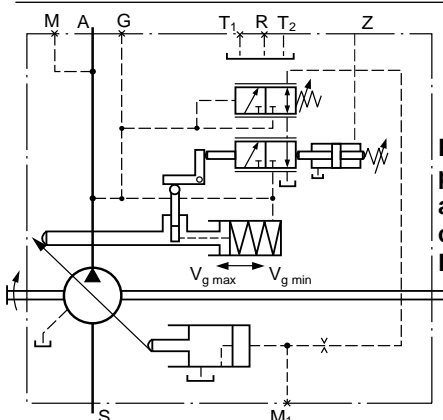

Power control with pressure cut-off and load limiting control, positive, LG2D

# HD Hydraulic Control, Pilot Pressure Related

The pilot pressure related hydraulic control allows stepless setting of the pump displacement in relation to pilot pressure. Control is proportional to the pilot pressure applied to port Y (max. 40 bar).

Control from  $V_{g\ min}$  to  $V_{g\ max}$ \*

In unoperated (zero pressure) condition, the pump is swivelled to its starting position ( $V_{g\ max}$ ) by means of a control spring.

At operating pressure > 30 bar the pump swivels from  $V_{g\ max}$  to  $V_{g\ min}$  (pilot pressure < start of control).

A pressure of 30 bar is needed for the control. The oil required for this is taken either from the high pressure or from the external adjustment pressure at port G ( $\geq 30$  bar).

If the operating pressure is  $\geq 30$  bar and  $V_{g\ min} > 0$  no external control pressure is required and port G should be plugged before commissioning. If port G is not to be used then the parts of the shuttle valve are to be removed from the pump (see note on repair instructions RDE 92500-R).

## HD1

Pilot pressure increase  $V_{g\ min}$ - $V_{g\ max}$  \_\_\_\_\_  $\Delta p = 10$  bar

Start of control, settable \_\_\_\_\_ 4 - 10 bar

When ordering, please state required start of control in clear text.

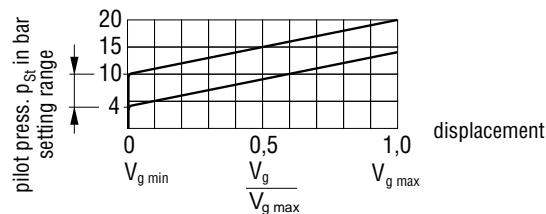

## HD2

Pilot pressure increase  $V_{g\ min}$ - $V_{g\ max}$  \_\_\_\_\_  $\Delta p = 25$  bar

Start of control, settable \_\_\_\_\_ 4 - 10 bar

When ordering, please state required start of control in clear text.

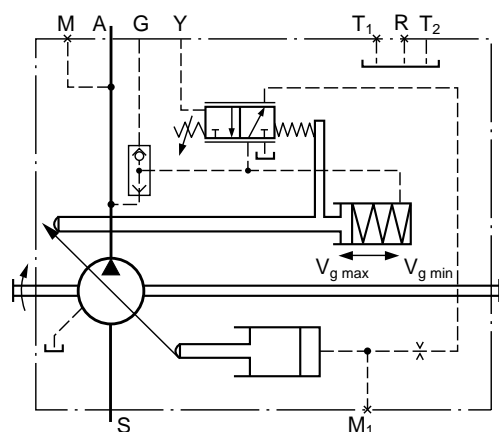
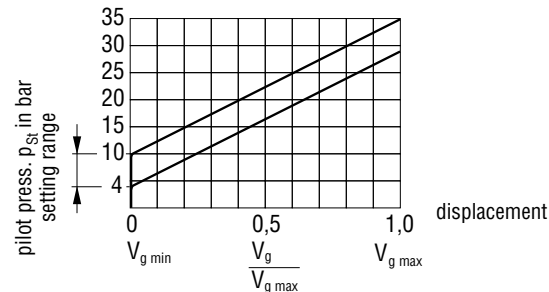

Hydraulic control, pilot pressure related, HD1, HD2

## Variation: Pressure cut-off (HD1D, HD2D)

The pressure cut-off is in effect a constant pressure control which swivels the pump back to  $V_{g\ min}$  when the preset operating pressure is reached.

This function overrides the hydraulic control, i.e. the hydraulic control is effective below the preset operating pressure.

The valve is integrated into the control housing and is set in the factory to a fixed pressure.

Setting range from 50 to 350 bar

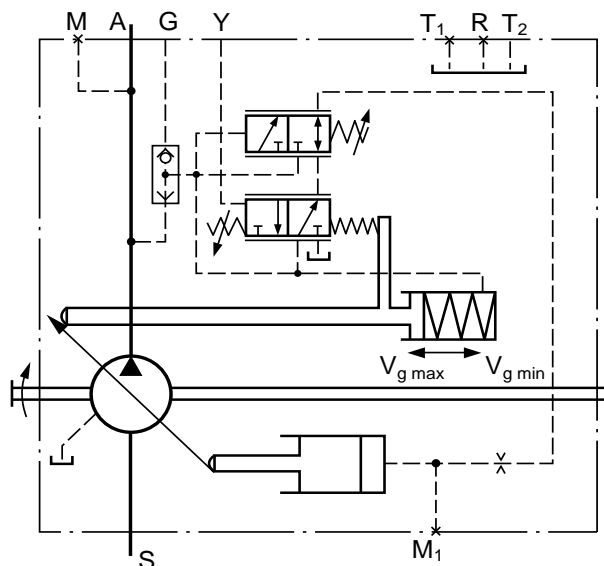
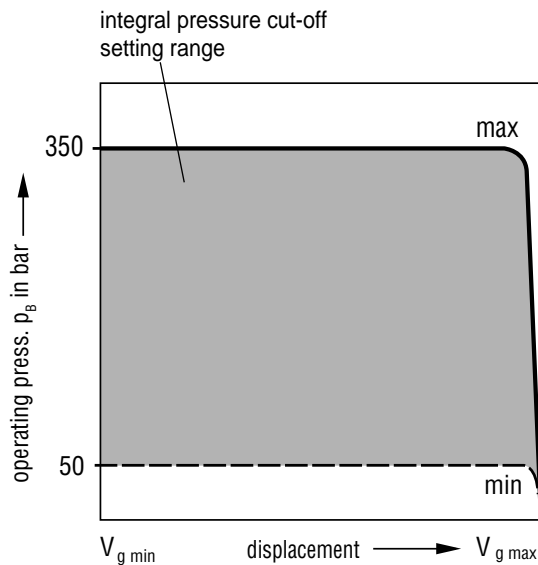

Hydraulic control, pilot pressure related, with integral pressure cut-off (fixed setting), HD1D, HD2D

# EP Electrical Control with Proportional Solenoid

Electrical control allows stepless and programmable setting of the pump displacement. Control is proportional to solenoid force (current strength). The control force at the control piston is generated by a proportional solenoid valve.

A 12V DC (EP1) or a 24V DC (EP2) supply is required for the control of the proportional solenoid.

Start of control at approx.: 400 mA (EP1)    200 mA (EP2)  
 End of control at approx.: 1200 mA (EP1)    600 mA (EP2)

Insulation class IP 54, control from  $V_{g\ min}$  to  $V_{g\ max}$

In unoperated (zero pressure) condition, the pump is swivelled to its starting position ( $V_{g\ max}$ ) by means of a control spring.

At operating pressure  $> 30$  bar the pump swivels from  $V_{g\ max}$  to  $V_{g\ min}$  (pilot current  $<$  start of control).

A pressure of 30 bar is needed for the control. The oil required for this is taken either from the high pressure or from the external adjustment pressure at port G ( $\geq 30$  bar).

If the operating pressure is  $\geq 30$  bar and  $V_{g\ min} > 0$  no external control pressure is required and port G should be plugged before commissioning. If port G is not to be used then the parts of the shuttle valve are to be removed from the pump (see note on repair instructions RDE 92500-R).

### Operating curve: EP2

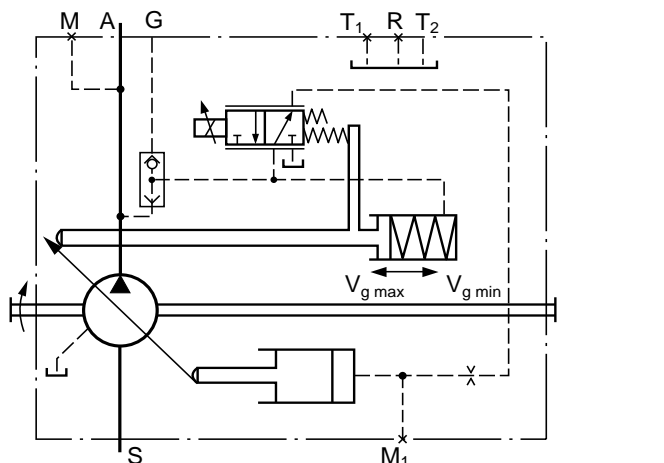
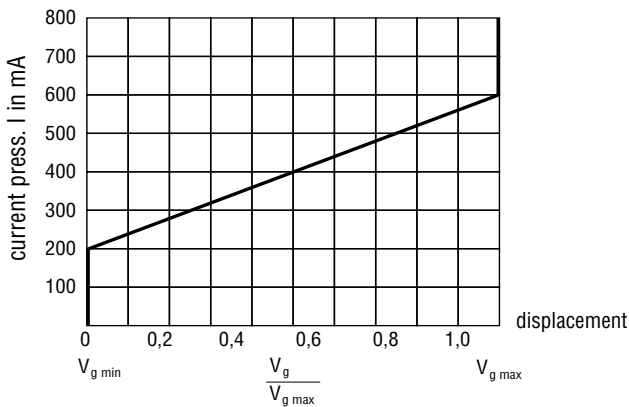

Electrical control with proportional solenoid, EP

The following are used for control of the proportional solenoid:

- Proportional amplifier **PV** \_\_\_\_\_ (see RE 95023)
- Proportional amplifier **VT 2000** \_\_\_\_\_ (see RE 29908)
- Chopper amplifier **CV** \_\_\_\_\_ (see RE 95029)

### Variation: Pressure cut-off (EP.D)

The pressure cut-off is in effect a constant pressure control which swivels the pump back to  $V_{g\ min}$  when the preset operating pressure is reached.

This function overrides the EP control, i.e. the EP control is effective below the preset operating pressure.

The valve is integrated into the control housing and is set in the factory to a fixed pressure.

Setting range from 50 to 350 bar

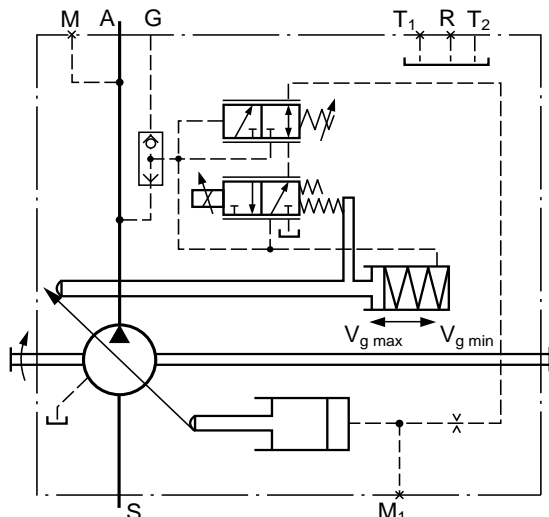
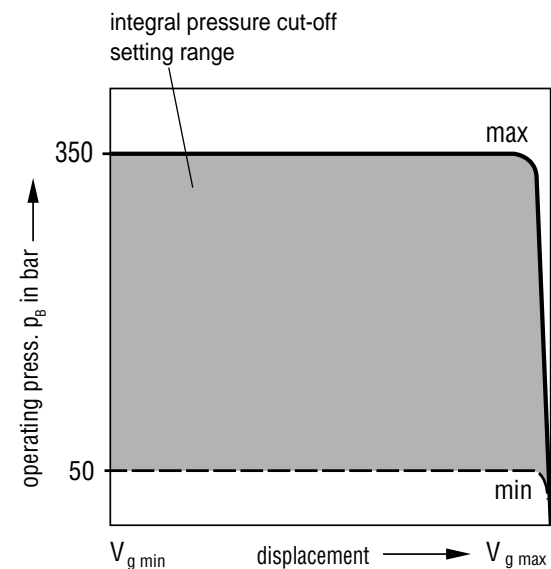

Electrical control with proportional solenoid and integral pressure cut-off (fixed setting), EP2D

Note:

Pumps with EP control may only be mounted within an oil tank when using mineral hydraulic oils and with oil temperatures in the tank of max. 80° C.

### Unit Dimensions, Size 40

Constant power control LR    Constant pressure control DR  
 Variation:                              Variation:  
 Pressure cut-off D                      Load sensing valve S  
 Load sensing valve S

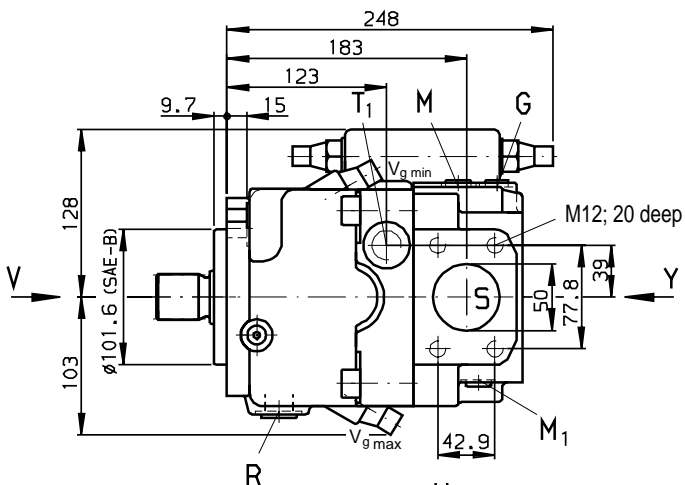

Detail V

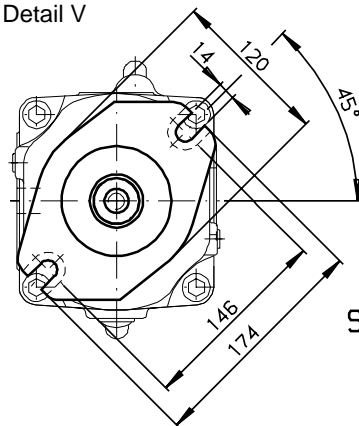

View Y  
anti-clockwise rotation

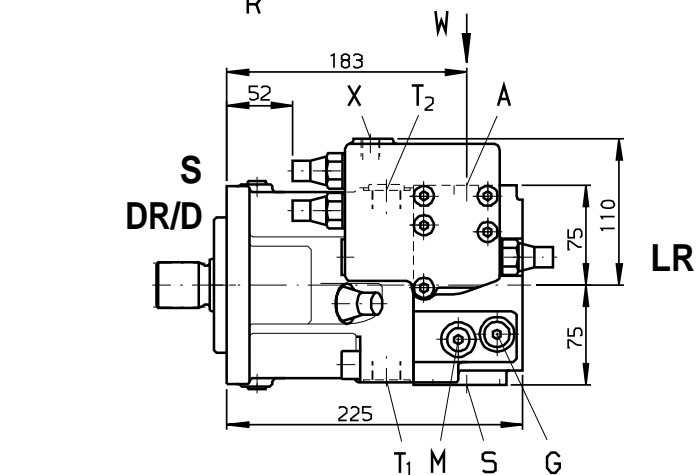
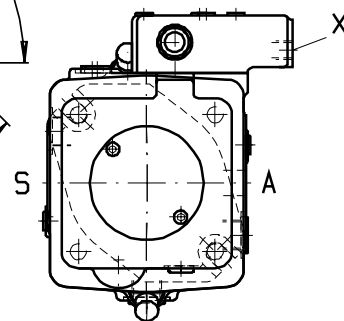

Detail W

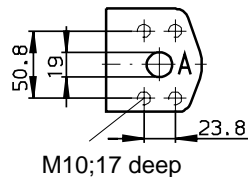

clockwise rotation

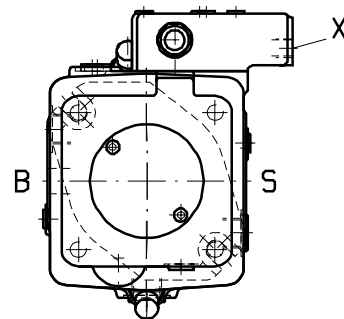

#### Shaft ends

**Z**  
 Splined shaft, DIN 5480  
 W 35x2x30x16x9g

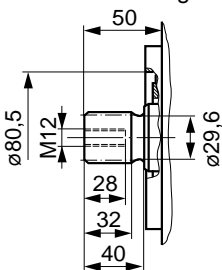

**P**  
 Parallel shaft, DIN 6885  
 with key AS 10x8x56

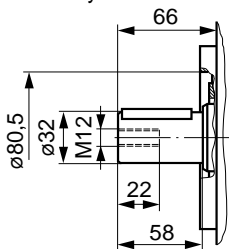

**S**  
 Splined shaft SAE B-B, 1"  
 pressure angle 30°, 15T-16/32 pitch  
 flat root, side fit  
 tolerance class 5, ANSI B92.1a/1976

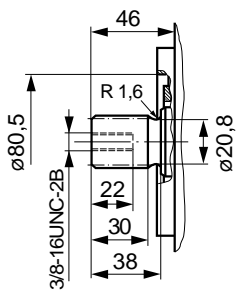

**T**  
 Splined shaft SAE C, 1 1/4"  
 pressure angle 30°, 14T-12/24 pitch  
 flat root, side fit  
 tolerance class 5, ANSI B92.1a/1976

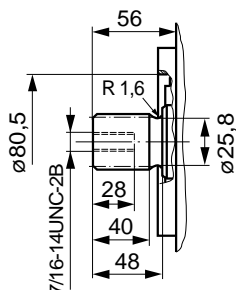

#### Connections

A, B Service line ports	SAE 3/4" 420 bar (6000 psi) high pressure series
S Suction port	SAE 2" 210 bar (3000 psi) standard series
T <sub>1</sub> Air bleed, tank	M22x1,5; 14 deep
T <sub>2</sub> Air bleed, tank	M22x1,5; 14 deep
M <sub>1</sub> Gauge point positioning chamber	M12x1,5; 12 deep
M Gauge point for pressure port	M12x1,5; 12 deep
X Port for Δp-control	M14x1,5; 12 deep
Y Pilot pressure port	M14x1,5; 12 deep
R Air bleed, Oil drain	M22x1,5; 14 deep
G Control pressure port	M14x1,5; 12 deep

at design with stroke limiter (H., U2),  
 or HD, EP-control with fitting GE10 - PLM  
 (in other case is port "G" closed)

### Unit Dimensions, Size 40

Constant power control with hydraulic stroke limiter and pressure cut-off LRDH1/LRDH5 (function:  $V_{g\ max}$  to  $V_{g\ min}$ )

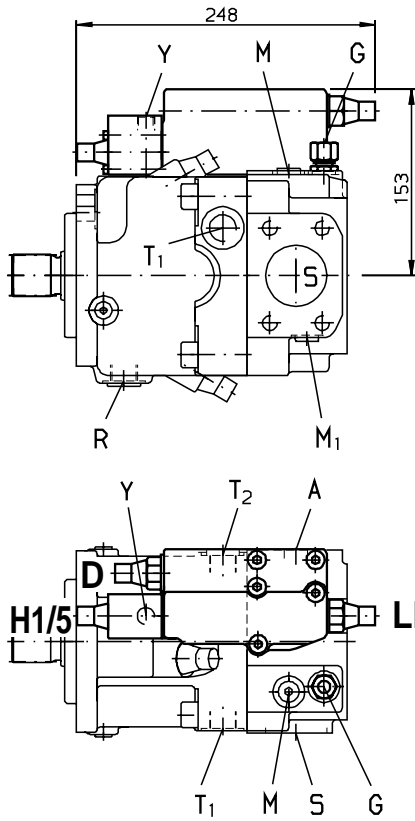

Constant power control with hydraulic stroke limiter and pressure cut-off LRDH2/LRDH6 (function:  $V_{g\ min}$  to  $V_{g\ max}$ )

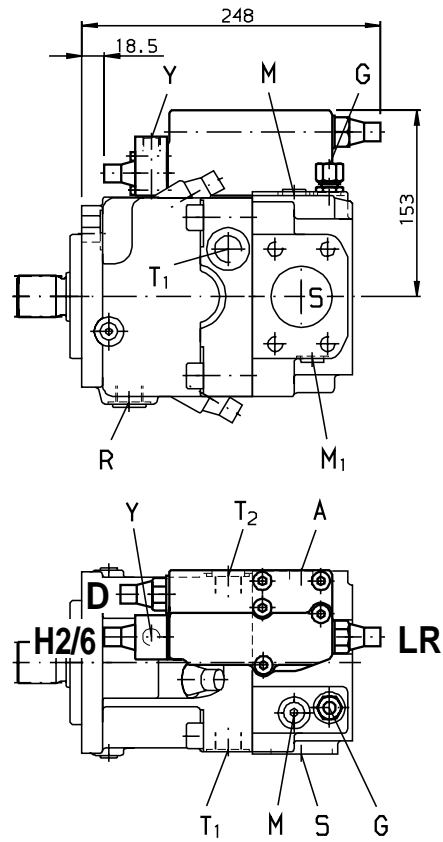

Hydraulic control, pilot pressure related, Pressure cut-off HD1D, HD2D

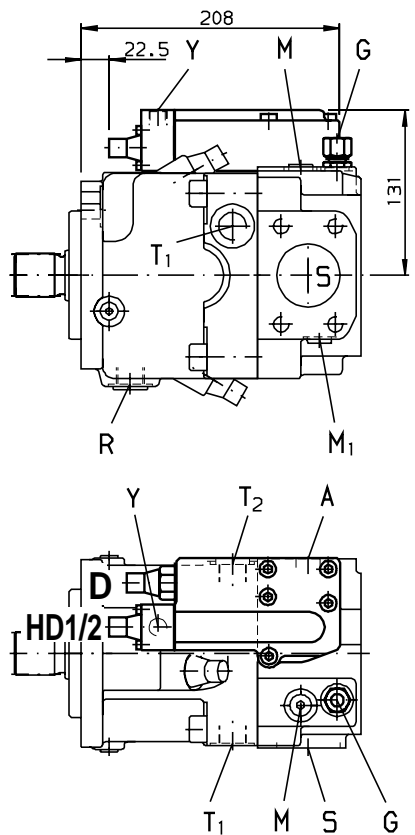

Electrical control with proportional solenoid, pressure cut-off EP.D (in preparation)

### Unit Dimensions, Size 60

Constant power control LR    Constant pressure control DR  
 Variation:                              Variation:  
 Pressure cut-off D                      Load sensing valve S  
 Load sensing valve S

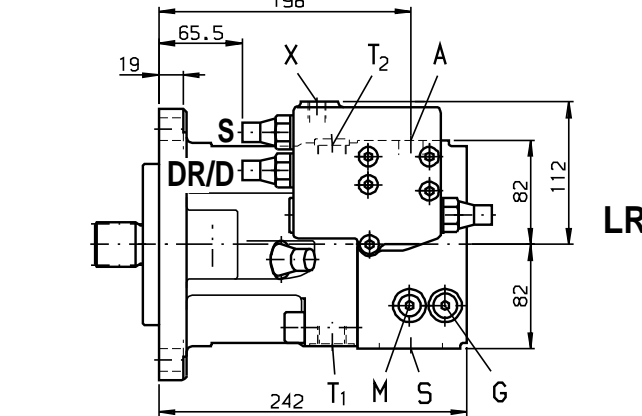
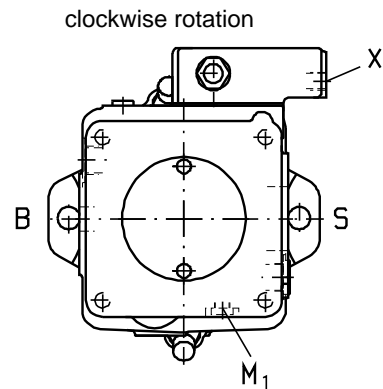
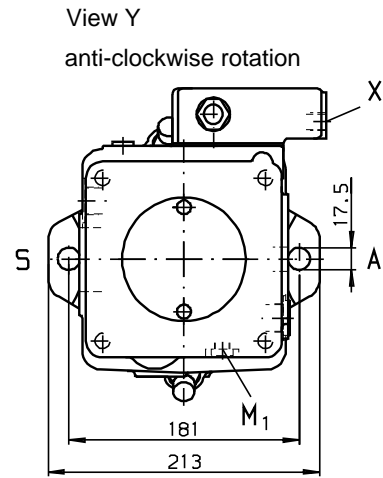
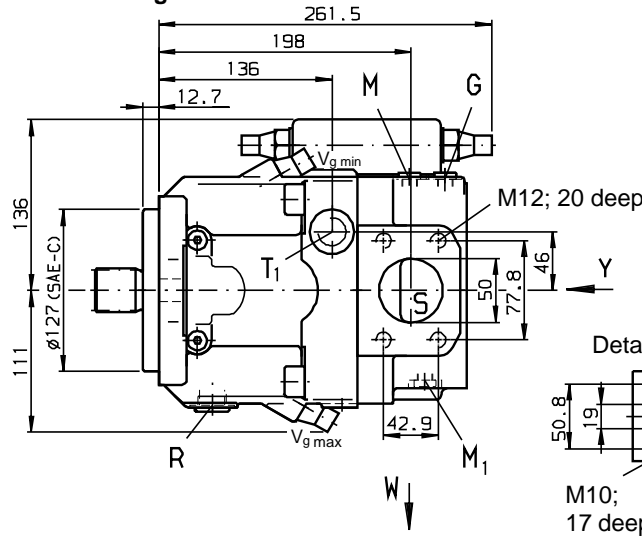

#### Shaft ends

**Z**  
 Splined shaft, DIN 5480  
 W 35x2x30x16x9g

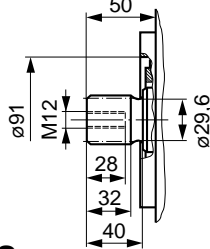

**P**  
 Parallel shaft, DIN 6885  
 with key AS 10x8x56

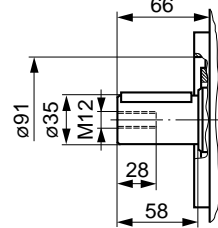

**S**  
 Splined shaft SAE C, 1 1/4"  
 pressure angle 30°, 14T-12/24 pitch  
 flat root, side fit  
 tolerance class 5, ANSI B92.1a/1976

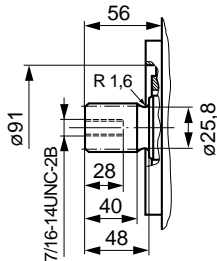

**T**  
 Splined shaft SAE 1 3/8"  
 pressure angle 30°, 21T-16/32 pitch  
 flat root, side fit  
 tolerance class 5, ANSI B92.1a/1976

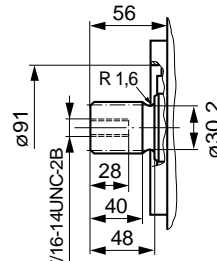

#### Connections

- A, B Service line ports                      SAE 3/4" 420 bar (6000 psi) high pressure series
  - S Suction port                                      SAE 2" 210 bar (3000 psi) standard series
  - T<sub>1</sub> Air bleed, tank                                  M22x1,5; 14 deep
  - T<sub>2</sub> Air bleed, tank                                  M22x1,5; 14 deep
  - M<sub>1</sub> Gauge point positioning chamber          M12x1,5; 12 deep
  - M Gauge point for pressure port              M12x1,5; 12 deep
  - X Port for Δp-control                              M14x1,5; 12 deep
  - Y Pilot pressure port                              M14x1,5; 12 deep
  - R Air bleed, Oil drain                              M22x1,5; 14 deep
  - G Control pressure port                              M14x1,5; 12 deep
- at design with stroke limiter (H., U2), or HD, EP-control with fitting GE10 - PLM (in other case is port "G" closed)



### Unit Dimensions, Size 60

Constant power control with hydraulic stroke limiter and pressure cut-off LRDH1/LRDH5 (function:  $V_{g\ max}$  to  $V_{g\ min}$ )

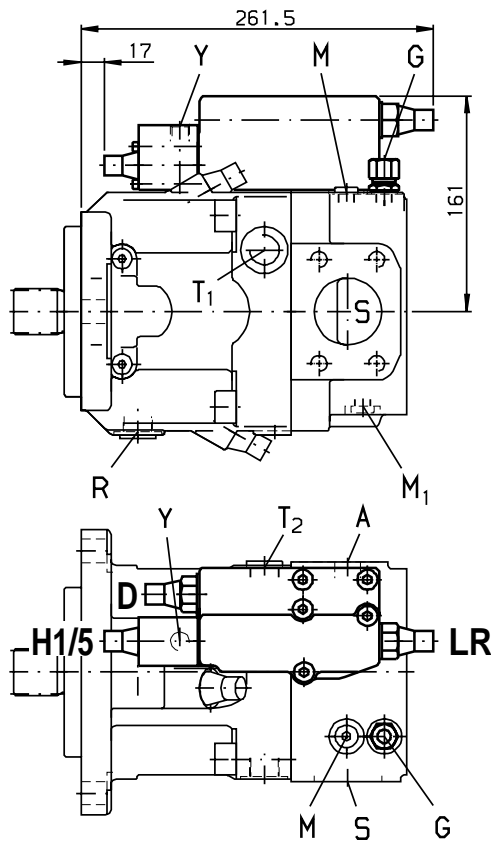

Constant power control with hydraulic stroke limiter and pressure cut-off LRDH2/LRDH6 (function:  $V_{g\ min}$  to  $V_{g\ max}$ )

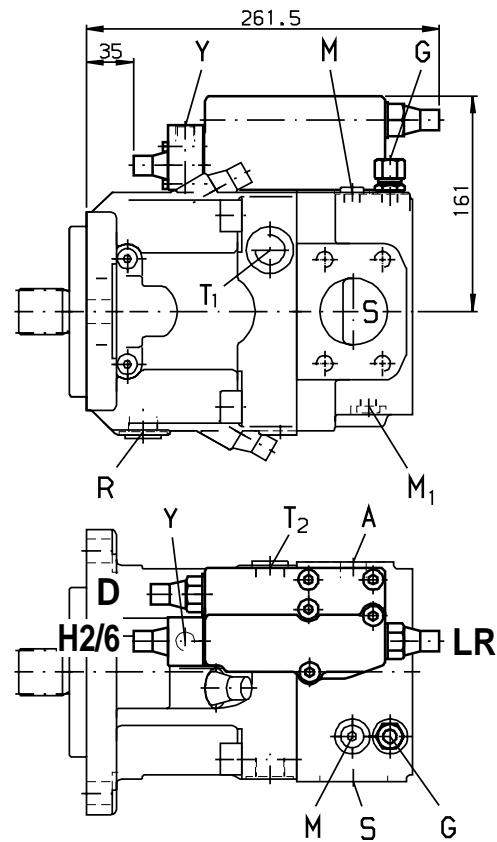

Hydraulic control, pilot pressure related, Pressure cut-off HD1D, HD2D

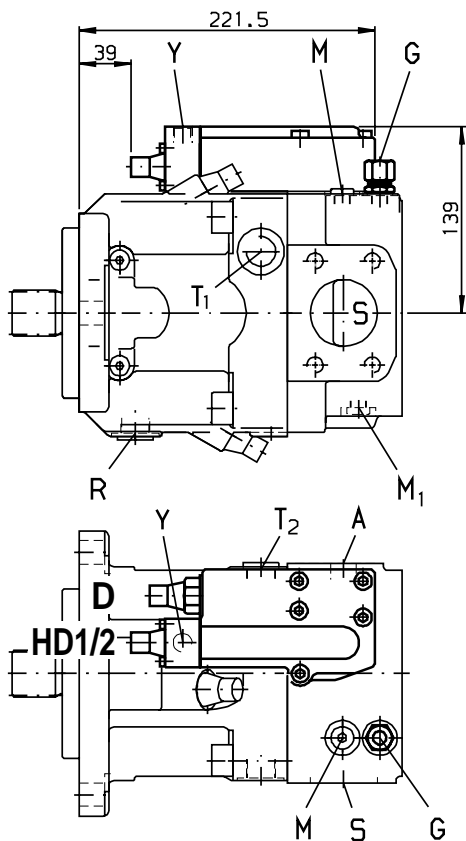

Electrical control with proportional solenoid, pressure cut-off EP.D

### Unit Dimensions, Size 75

Constant power control LR    Constant pressure control DR  
 Variation:                      Variation:  
 Pressure cut-off D            Load sensing valve S  
 Load sensing valve S

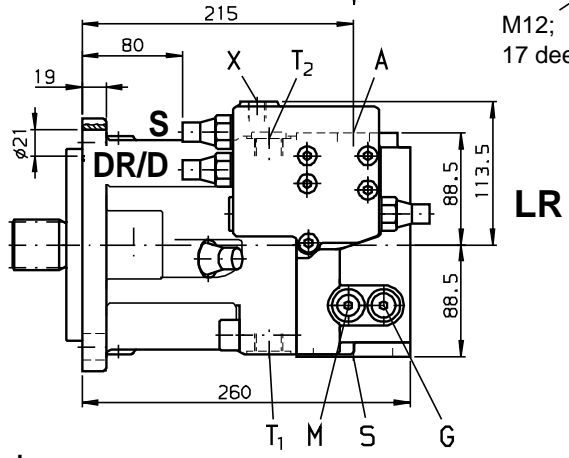
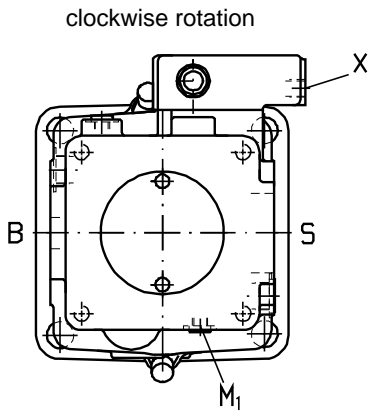
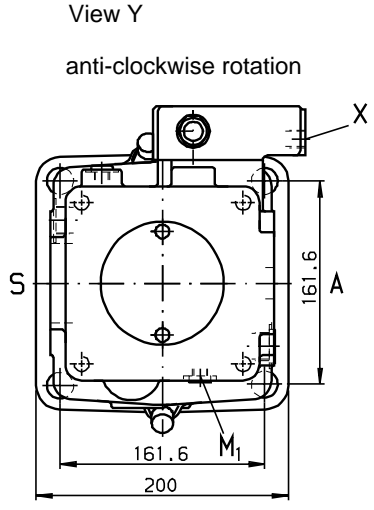
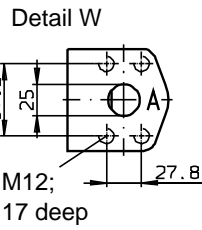
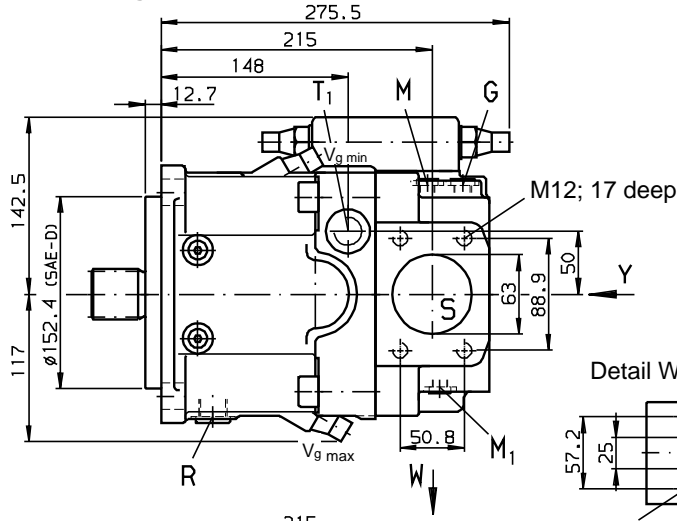

**Shaft ends**

**Z**  
 Splined shaft, DIN 5480  
 W 40x2x30x18x9g

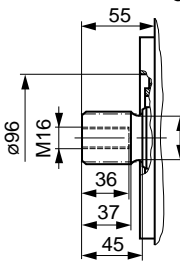

**P**  
 Parallel shaft, DIN 6885  
 with key AS 12x8x80

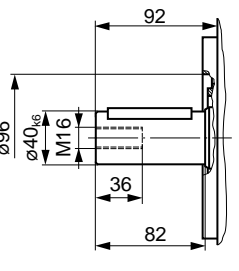

**S**  
 Splined shaft SAE C, 1 1/4"  
 pressure angle 30°, 14T-12/24 pitch  
 flat root, side fit  
 tolerance class 5, ANSI B92.1a/1976

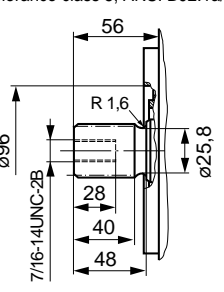

**T**  
 Splined shaft SAE 1 3/8"  
 pressure angle 30°, 21T-16/32 pitch  
 flat root, side fit  
 tolerance class 5, ANSI B92.1a/1976

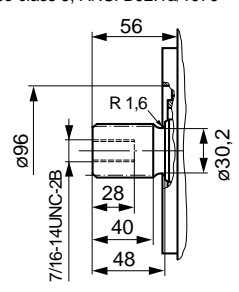

**Connections**

- A, B Service line ports                      SAE 1" 420 bar (6000 psi) high pressure series
  - S Suction port                                    SAE 2 1/2" 170 bar (2500 psi) standard series
  - T<sub>1</sub> Air bleed, tank                                M22x1,5; 14 deep
  - T<sub>2</sub> Air bleed, tank                                M22x1,5; 14 deep
  - M<sub>1</sub> Gauge point positioning chamber        M12x1,5; 12 deep
  - M Gauge point for pressure port            M12x1,5; 12 deep
  - X Port for Δp-control                            M14x1,5; 12 deep
  - Y Pilot pressure port                            M14x1,5; 12 deep
  - R Air bleed, Oil drain                           M22x1,5; 14 deep
  - G Control pressure port                        M14x1,5; 12 deep
- at design with stroke limiter (H., U2), or HD, EP-control with fitting GE10 - PLM (in other case is port "G" closed)

### Unit Dimensions, Size 75

Constant power control with hydraulic stroke limiter and pressure cut-off LRDH1/LRDH5 (function:  $V_{g\max}$  to  $V_{g\min}$ )

Constant power control with hydraulic stroke limiter and pressure cut-off LRDH2/LRDH6 (function:  $V_{g\min}$  to  $V_{g\max}$ )

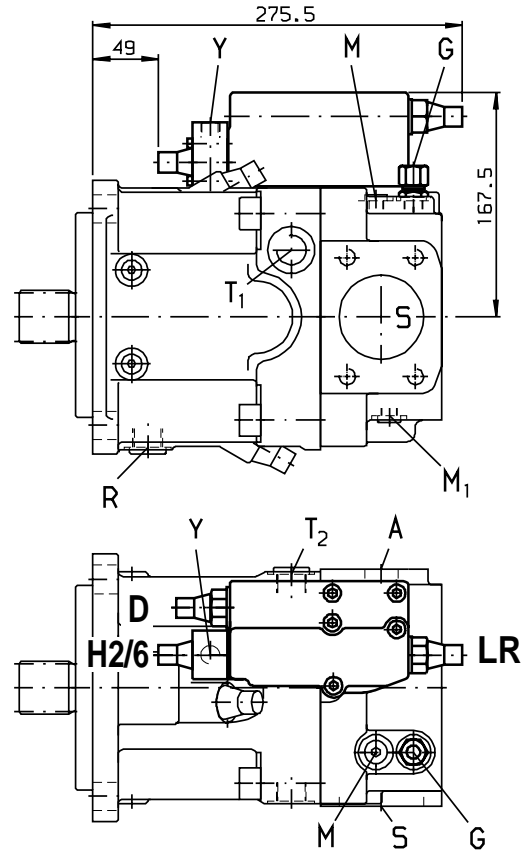
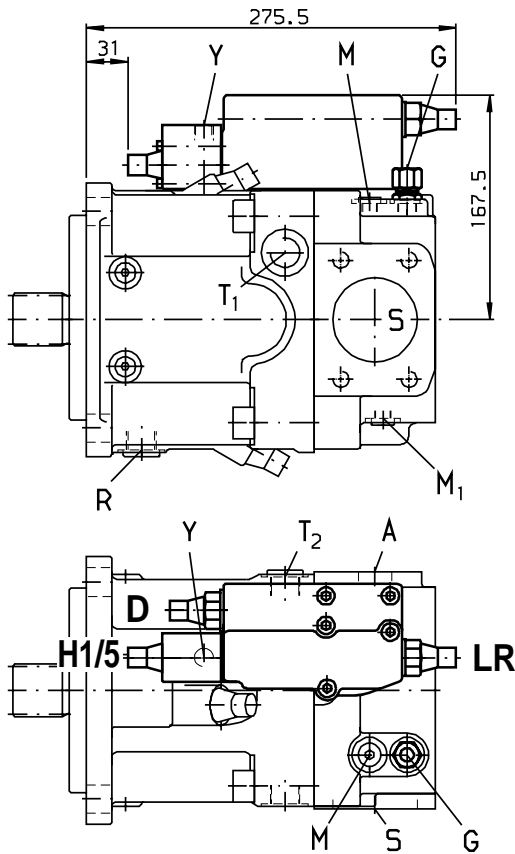

Hydraulic control, pilot pressure related, pressure cut-off HD1D, HD2D

Electrical control with proportional solenoid, pressure cut-off EP.D

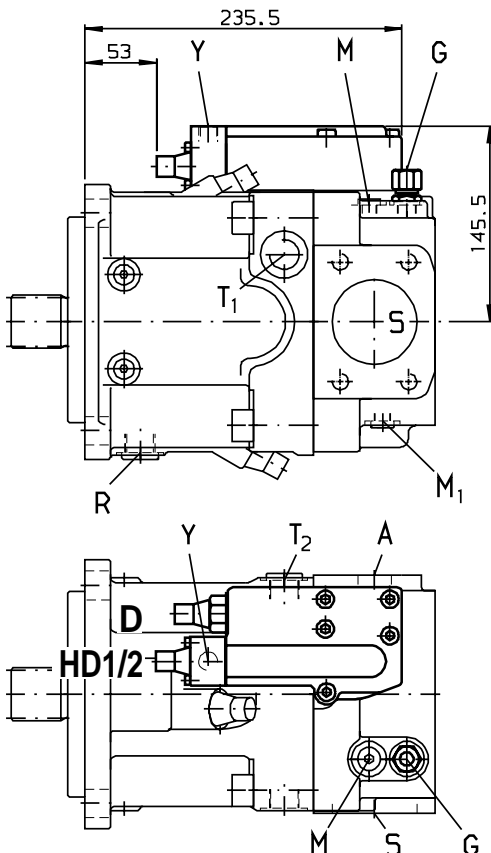

### Unit Dimensions, Size 95

Constant power control LR    Constant pressure control DR  
 Variation:                      Variation:  
 Pressure cut-off D            Load sensing valve S  
 Load sensing valve S

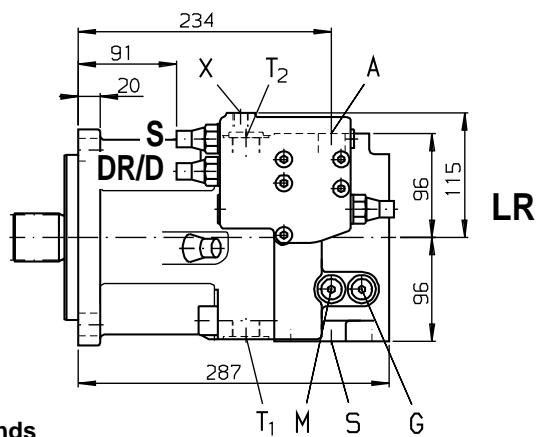
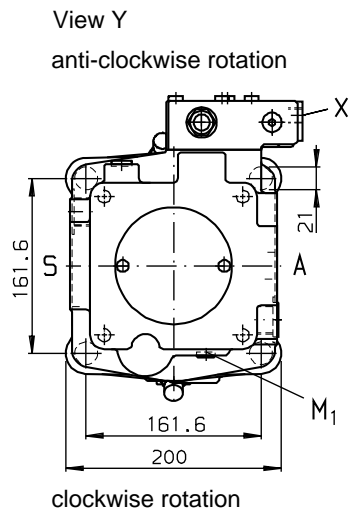
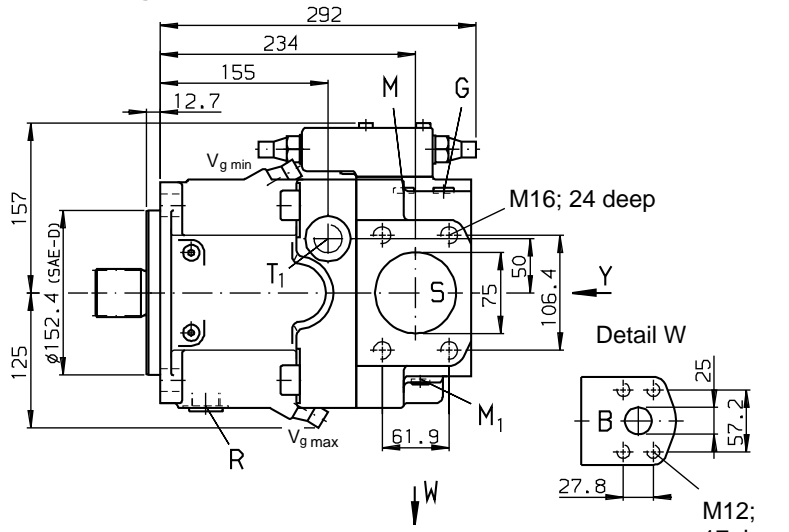

#### Shaft ends

**Z**  
 Splined shaft, DIN 5480  
 W 45x2x30x21x9g

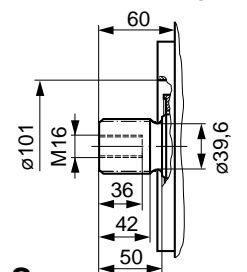

**P**  
 Parallel shaft, DIN 6885  
 with key AS 14x9x80

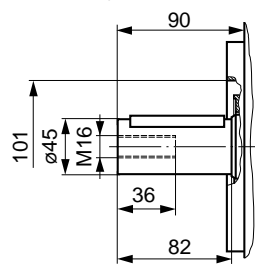

**S**  
 Splined shaft SAE D, 1 3/4"  
 pressure angle 30°, 13T-8/16 pitch  
 flat root, side fit  
 tolerance class 5, ANSI B92.1a/1976

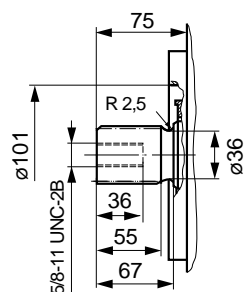

#### Connections

A, B Service line ports	SAE 1" 420 bar (6000 psi) high pressure series
S Suction port	SAE 3" 140 bar (2000 psi) standard series
T <sub>1</sub> Air bleed, tank	M26x1,5; 14 deep
T <sub>2</sub> Air bleed, tank	M26x1,5; 14 deep
M <sub>1</sub> Gauge point positioning chamber	M12x1,5; 12 deep
M Gauge point for pressure port	M12x1,5; 12 deep
X Port for Δp-control	M14x1,5; 12 deep
Y Pilot pressure port	M14x1,5; 12 deep
R Air bleed, Oil drain	M26x1,5; 14 deep
G Control pressure port	M14x1,5; 12 deep

at design with stroke limiter (H..., U2), or HD, EP-control with fitting GE10 - PLM (in other case is port "G" closed)

### Unit Dimensions, Size 95

Constant power control with hydraulic stroke limiter and pressure cut-off LRDH1/LRDH5 (function:  $V_{g \max}$  to  $V_{g \min}$ )

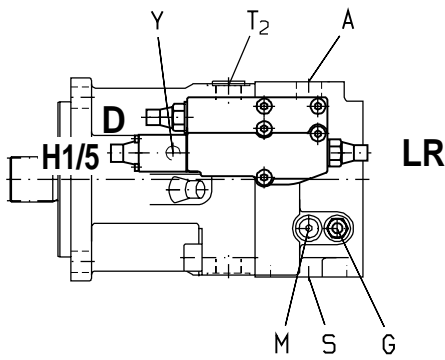
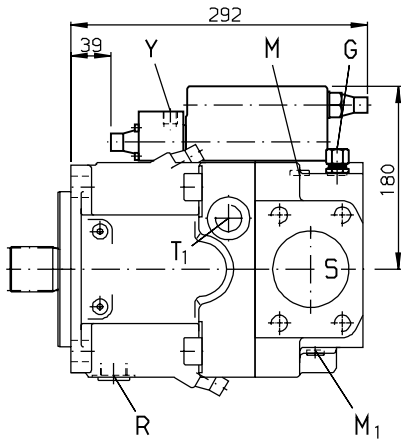

Constant power control with hydraulic stroke limiter and pressure cut-off LRDH2/LRDH6 (function:  $V_{g \min}$  to  $V_{g \max}$ )

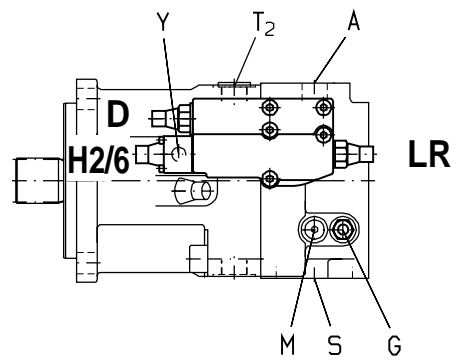
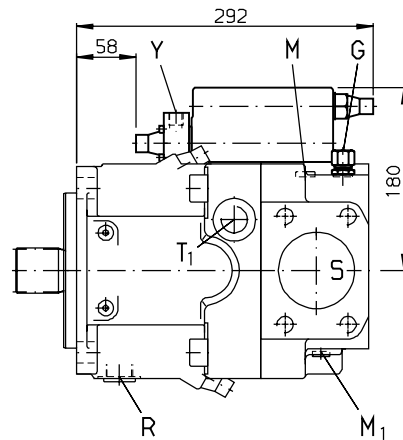

Hydraulic control, pilot pressure related, pressure cut-off HD1D, HD2D

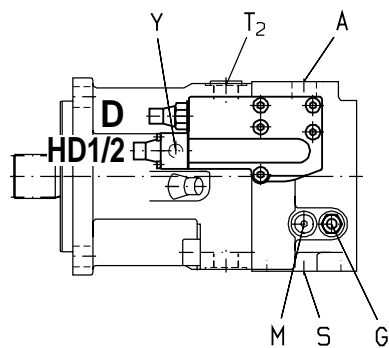
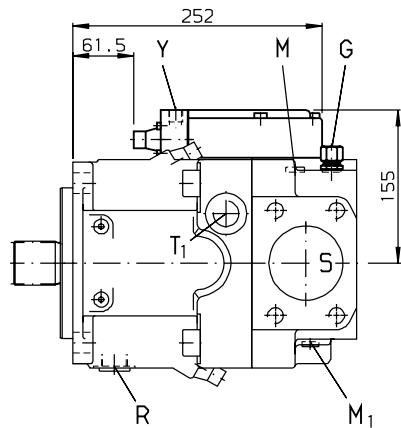

Electrical control with proportional solenoid, pressure cut-off EP.D

### Unit Dimensions, Size 130

Constant power control LR    Constant pressure control DR  
 Variation:                      Variation:  
 Pressure cut-off D            Load sensing valve S  
 Load sensing valve S

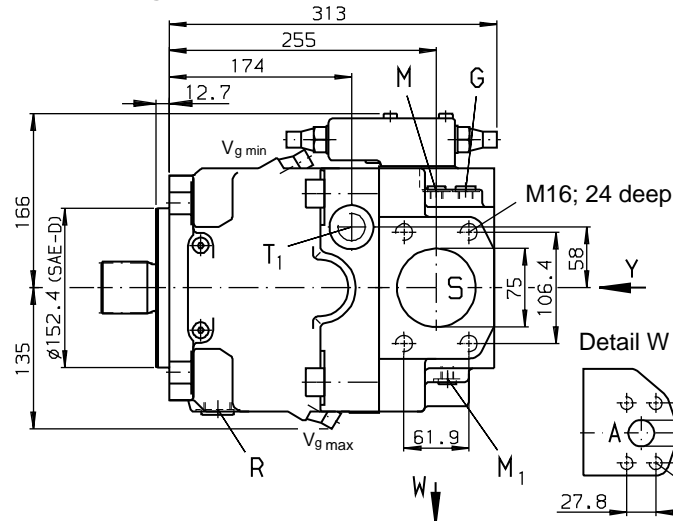

View Y  
anti-clockwise rotation

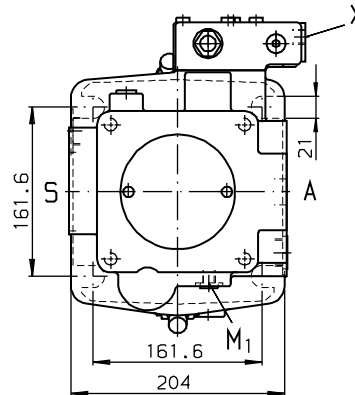

clockwise rotation

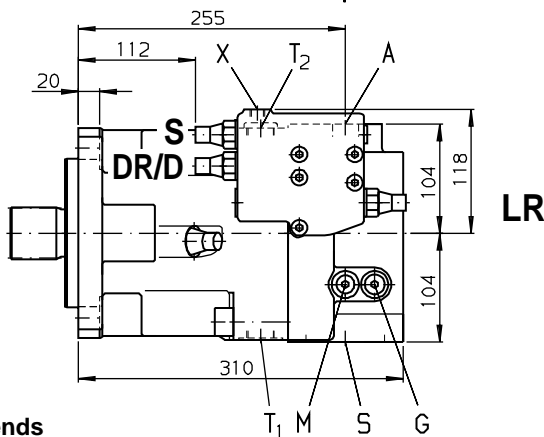
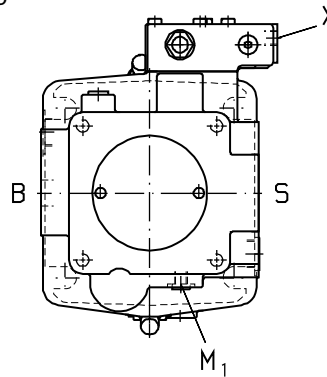

#### Shaft ends

**Z**  
Splined shaft, DIN 5480  
W 50x2x30x24x9g

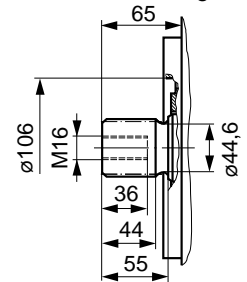

**P**  
Parallel shaft, DIN 6885  
with key AS 14x9x80

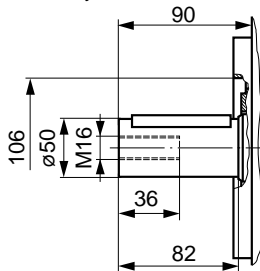

**S**  
Splined shaft SAE D, 1 3/4"  
pressure angle 30°, 13T-8/16 pitch  
flat root, side fit  
tolerance class 5, ANSI B92.1a/1976

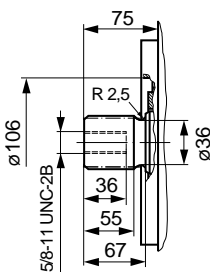

#### Connections

- A, B Service line ports (without impeller) SAE 1" 420 bar (6000 psi) high pressure series
- A, B Service line ports (with impeller) SAE 1 1/4" 420 bar (6000 psi) high pressure series
- S Suction port SAE 3" 140 bar (2000 psi) standard series
- T<sub>1</sub> Air bleed, tank M26x1,5; 14 deep
- T<sub>2</sub> Air bleed, tank M26x1,5; 14 deep
- M<sub>1</sub> Gauge point positioning chamber M12x1,5; 12 deep
- M Gauge point for pressure port M12x1,5; 12 deep
- X Port for Δp-control M14x1,5; 12 deep
- Y Pilot pressure port M14x1,5; 12 deep
- R Air bleed, Oil drain M26x1,5; 14 deep
- G Control pressure port M14x1,5; 12 deep  
at design with stroke limiter (H., U2),  
or HD, EP-control with fitting GE10 - PLM  
(in other case is port "G" closed)

### Unit Dimensions, Size 130

Constant power control with hydraulic stroke limiter and pressure cut-off LRDH1/LRDH5 (function:  $V_{g\ max}$  to  $V_{g\ min}$ )

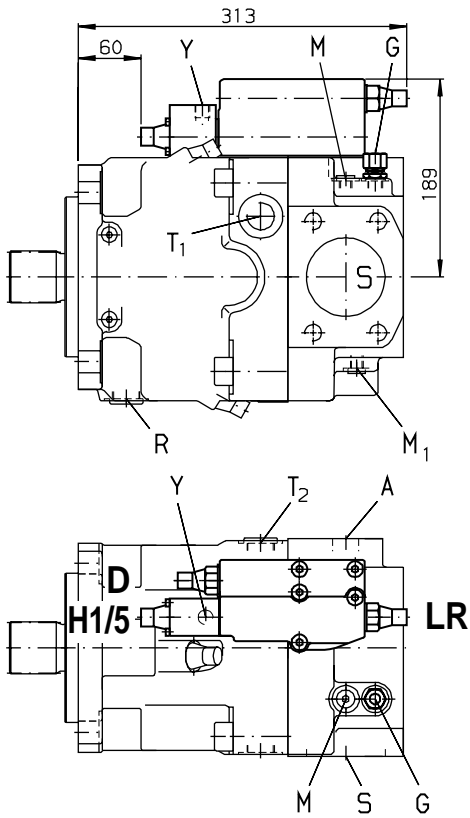

Constant power control with hydraulic stroke limiter and pressure cut-off LRDH2/LRDH6 (function:  $V_{g\ min}$  to  $V_{g\ max}$ )

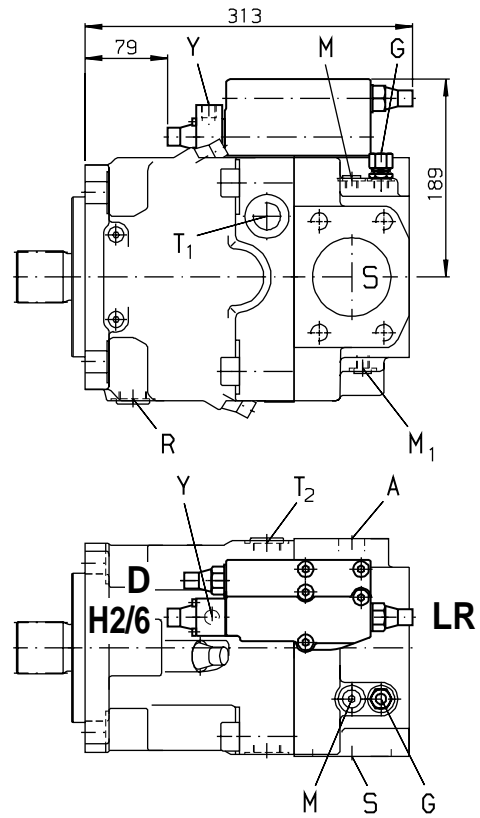

Hydraulic control, pilot pressure related, pressure cut-off HD1D, HD2D

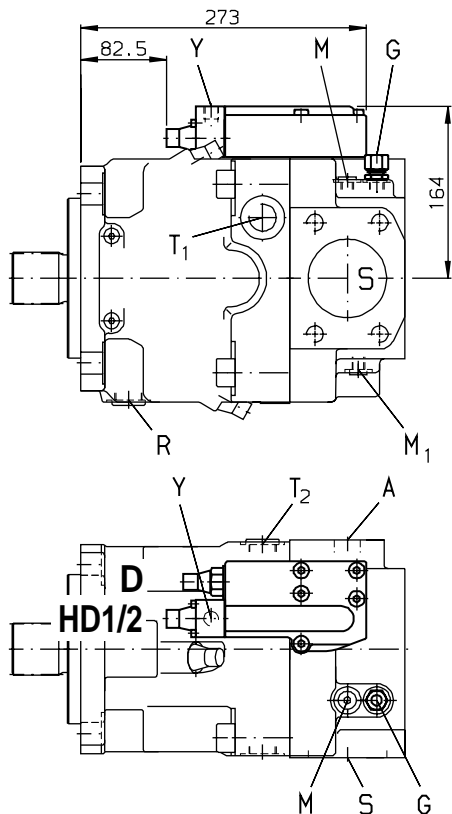

Design A11VLO (with charge pump, clockwise rotation) connections see page 22

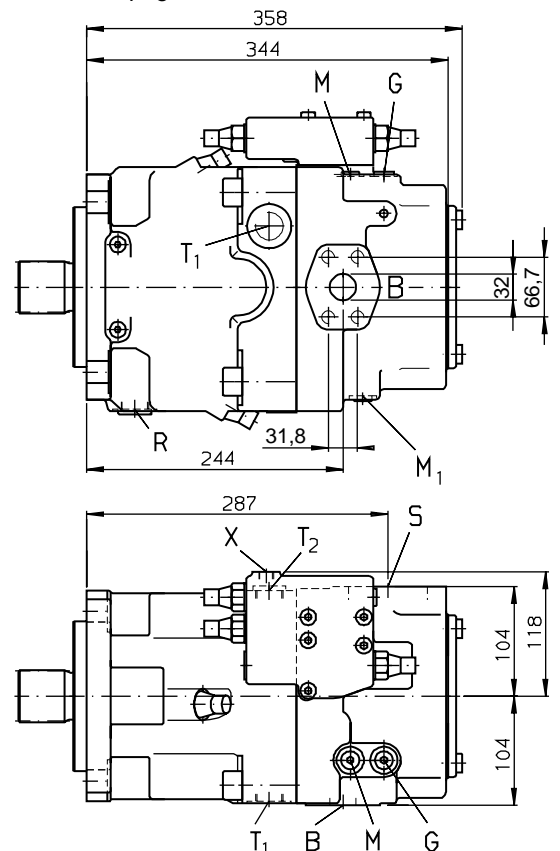

### Unit Dimensions, Size 190, design with charge pump

Constant power control, with pressure cut-off and Load sensing valve, LRDS

Constant pressure control with Load sensing valve, DRS

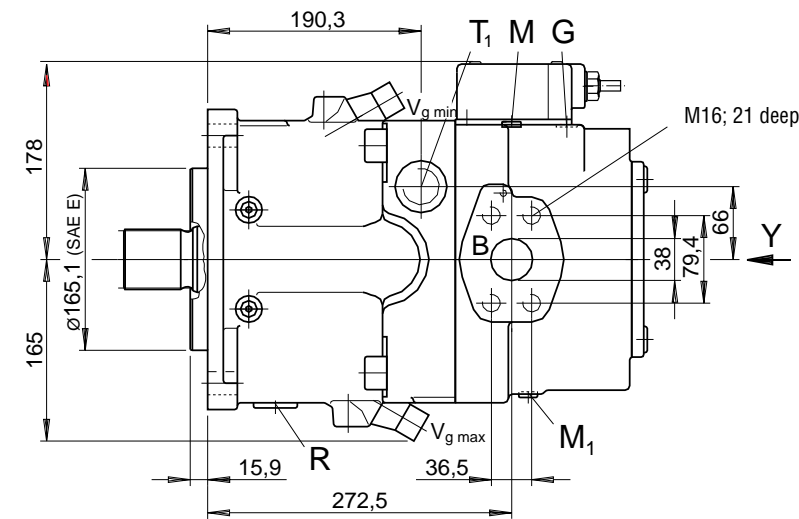

View Y, clockwise rotation

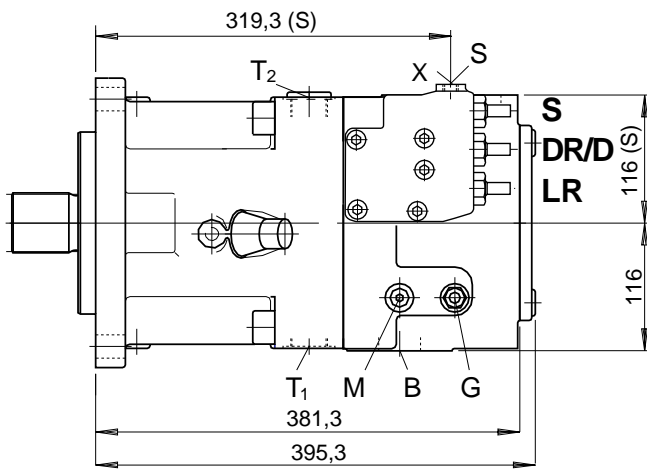
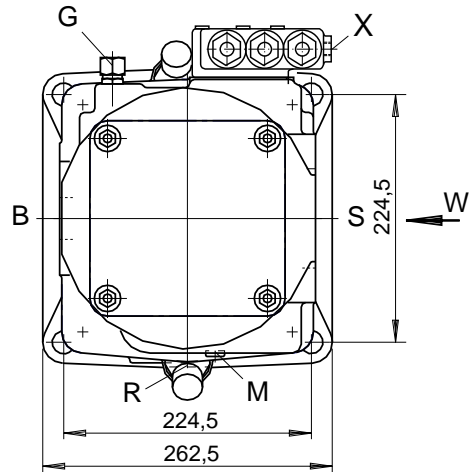

Detail W

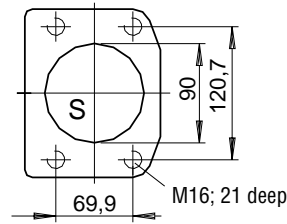

#### Shaft ends

**Z**

Spined shaft, DIN 5480  
W 50x2x30x24x9g

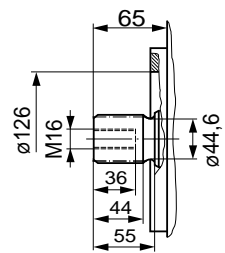

**P**

Parallel shaft, DIN 6885  
with key AS 16x10x100

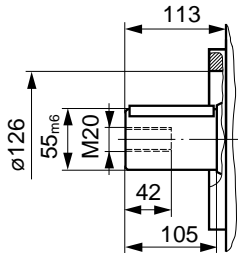

**S**

Spined shaft SAE D, 1 3/4" pressure angle 30°, 13T-8/16 pitch flat root, side fit tolerance class 5, ANSI B92.1a/1976

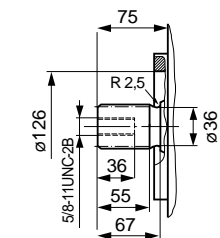

**T**

Spined shaft SAE F, 2" pressure angle 30°, 15T-8/16 pitch flat root, side fit tolerance class 5, ANSI B92.1a/1976

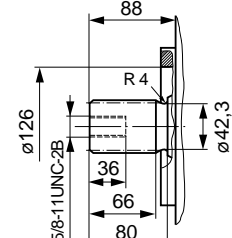

#### Connections

A, B Service line ports

S Suction port

T<sub>1</sub> Air bleed, tank

T<sub>2</sub> Air bleed, tank

M<sub>1</sub> Gauge point positioning chamber

M Gauge point for pressure port

X Port for Δp-control

Y Pilot pressure port

R Air bleed, Oil drain

G Control pressure port

at design with stroke limiter (H..., U2), or HD, EP-control with fitting GE10 - PLM (in other case is port "G" closed)

SAE 1 1/2" 420 bar (6000 psi) high pressure series  
SAE 3 1/2" 35 bar (500 psi) standard series

M33x2; 16 deep

M33x2; 16 deep

M12x1,5; 12 deep

M12x1,5; 12 deep

M14x1,5; 12 deep

M14x1,5; 12 deep

M33x2; 16 deep

M14x1,5; 12 deep



### Unit Dimensions, Size 190

Constant power control with hydraulic stroke limiter and pressure cut-off LRDH1/LRDH5 (function:  $V_{g\ max}$  to  $V_{g\ min}$ ) (without charge pump)

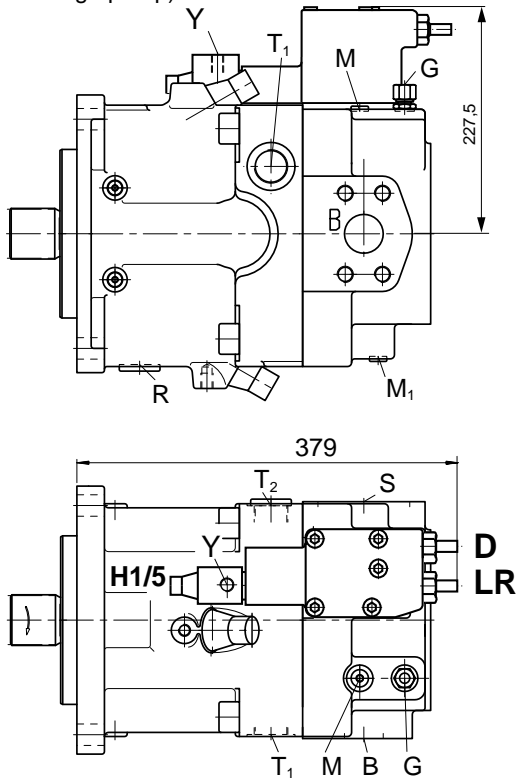

Constant power control with hydraulic stroke limiter and pressure cut-off LRDH2/LRDH6 (function:  $V_{g\ min}$  to  $V_{g\ max}$ )

Hydraulic control, pilot pressure related, pressure cut-off HD1D, HD2D

Design A11VO 190 (without charge pump, clockwise rotation), electrical control EP, connections see page 24

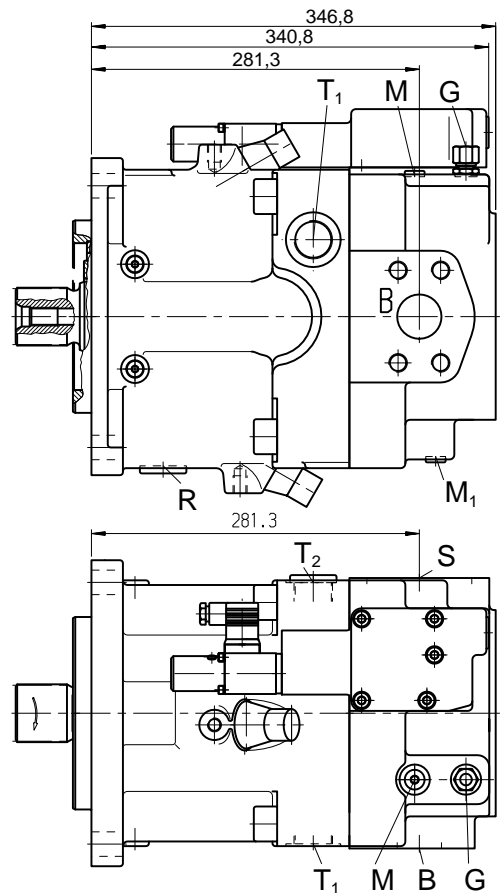

# Unit Dimensions, Size 260

Electrical control EP, design without charge pump

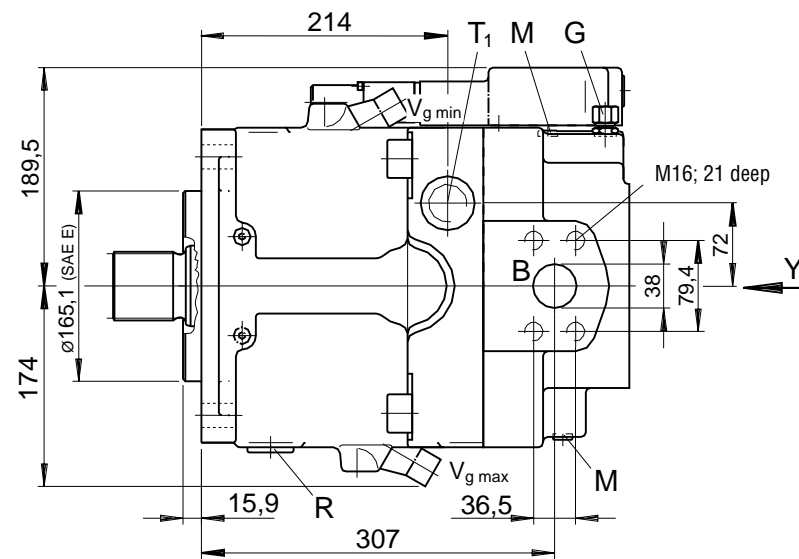

View Y  
clockwise rotation

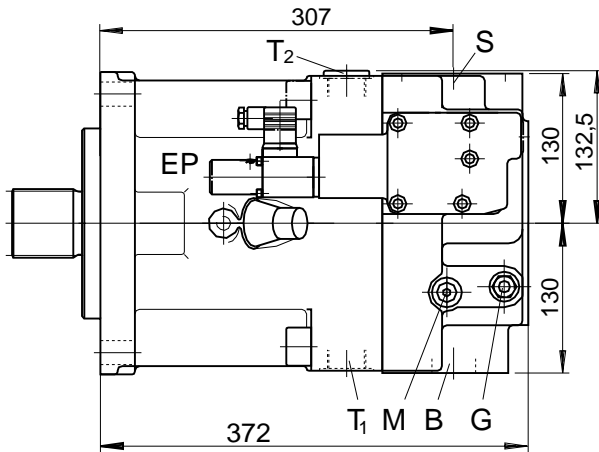
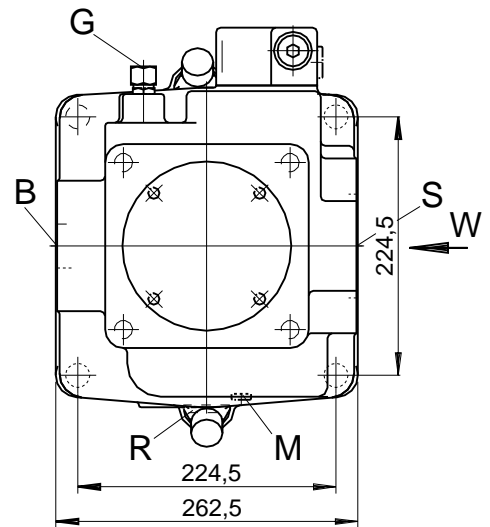

Detail W

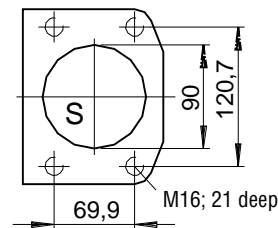

## Shaft ends

**Z**  
Splined shaft, DIN 5480  
W 60x2x30x28x9g

**P**  
Parallel shaft, DIN 6885  
with key AS 18x11x100

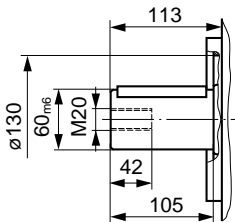
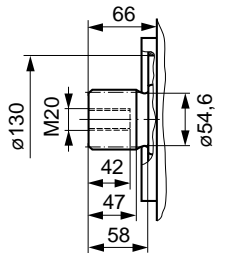

**S**  
Splined shaft SAE D, 1 3/4" pressure angle 30°, 13T-8/16 pitch flat root, side fit tolerance class 5, ANSI B92.1a/1976

**T**  
Splined shaft SAE 2 1/4" pressure angle 30°, 17T-8/16 pitch flat root, side fit tolerance class 5, ANSI B92.1a/1976

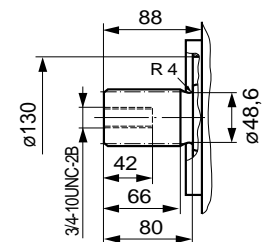
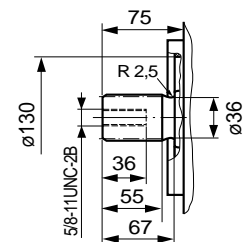

## Connections

- |                |  |  |
|----------------|--|--|
| A, B           | Service line ports                         | SAE 1 1/2" 420 bar (6000 psi) high pressure series |
| S              | Suction port ( <i>without</i> charge pump) | SAE 3 1/2" 35 bar (500 psi) standard series        |
| S              | Suction port ( <i>with</i> charge pump)    | SAE 4" 35 bar (500 psi) standard series            |
| T <sub>1</sub> | Air bleed, tank                            | M33x2; 16 deep                                     |
| T <sub>2</sub> | Air bleed, tank                            | M33x2; 16 deep                                     |
| M <sub>1</sub> | Gauge point positioning chamber            | M12x1,5; 12 deep                                   |
| M              | Gauge point for pressure port              | M12x1,5; 12 deep                                   |
| X              | Port for Δp-control                        | M14x1,5; 12 deep                                   |
| Y              | Pilot pressure port                        | M14x1,5; 12 deep                                   |
| R              | Air bleed, Oil drain                       | M33x2; 16 deep                                     |
| G              | Control pressure port                      | M14x1,5; 12 deep                                   |
- at design with stroke limiter (H., U2), or HD, EP-control with fitting GE10 - PLM (in other case is port "G" closed)

## Unit Dimensions, Size 260

Constant power control with hydraulic stroke limiter and pressure cut-off LRDH1/LRDH5 (function:  $V_{g \max}$  to  $V_{g \min}$ )

Constant power control with hydraulic stroke limiter and pressure cut-off LRDH2/LRDH6 (function:  $V_{g \min}$  to  $V_{g \max}$ )

Hydraulic control, pilot pressure related, pressure cut-off HD1D, HD2D

Design A11VLO 260 (with charge pump, clockwise rotation), electrical control EP, connections see page 26

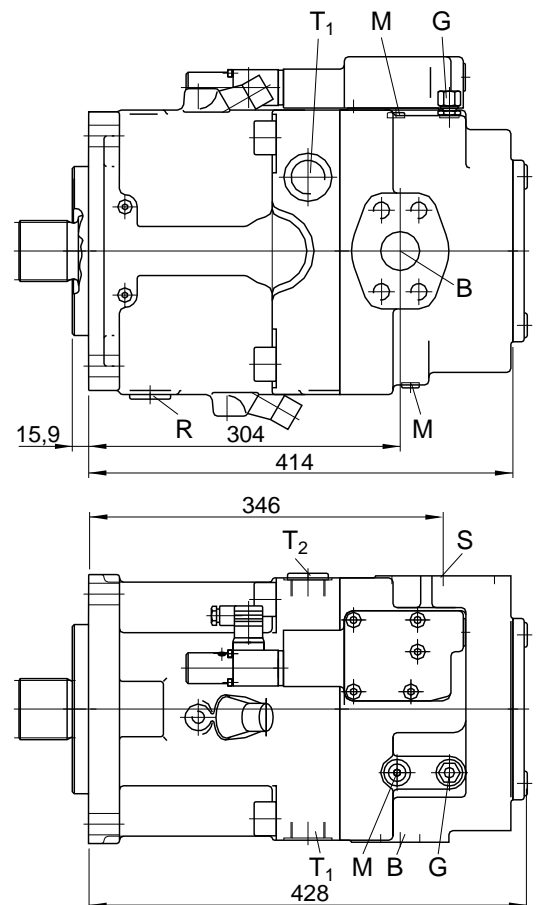

## Dimensions for Through Drives

### Through drive: flange SAE A, hub SAE A (K01)

M10; 15 deep (sizes 60, 75)  
M10; 12,5 deep (sizes 95-260)

splined hub SAE A N 5/8"-9T 16/32 DP

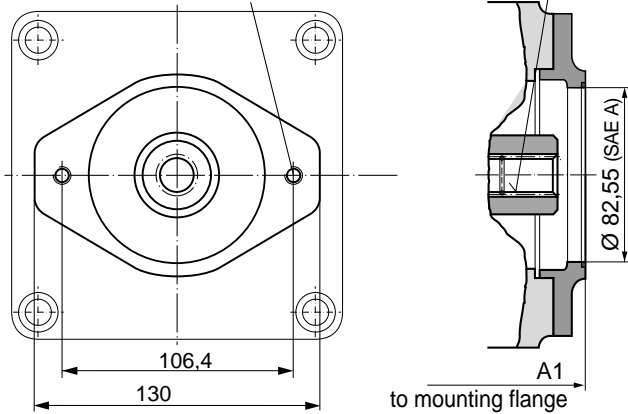

### Total length A1

hub	SAE A K01
size 40	
60	257
75	275
95	306
130	339
130*	
190	
190*	394
260	385
260*	427,3

\*) design with charge pump (impeller)

### Through drive: flange SAE B, hub - SAE B (K02) - SAE B-B (K04) - N 35 (K79)

splined hub SAE B N 7/8"-13T 16/32 DP  
splined hub SAE B-B N 1"-15T 16/32 DP  
splined hub DIN 5480 N 35x2x30x16x9H

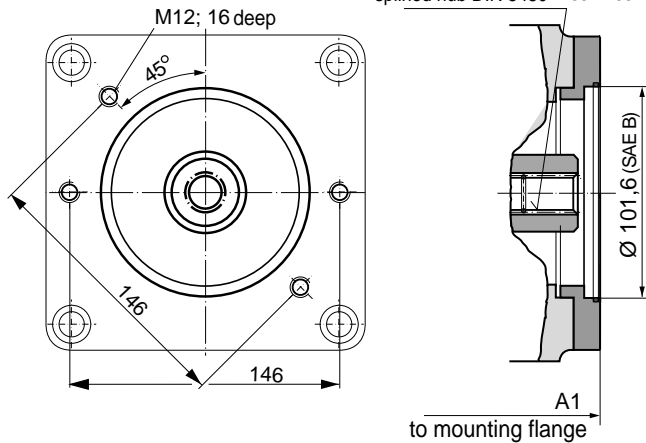

### Total length A1

hub	SAE B K02	SAE B-B K04	N35 K79
size 40			
60	261	261	
75	279	279	
95	303	303	303
130	326	326	326
130*			
190			
190*	404	404	394
260	395	395	395
260*	437,5	437,5	437,5

\*) design with charge pump (impeller)

### Through drive: flange SAE C, hub - SAE C (K07) - SAE C-C (K24) - N30 (K80) - N 35 (K61)

M16; 15 deep (sizes 60-95)  
M16; 20 deep (sizes 130-260)

splined hub SAE C-C N 1 1/2"-17T 12/24 DP  
splined hub SAE C N 1 1/4"-14T 12/24 DP  
splined hub DIN 5480 N 30x2x30x14x9H  
splined hub DIN 5480 N 35x2x30x16x9H

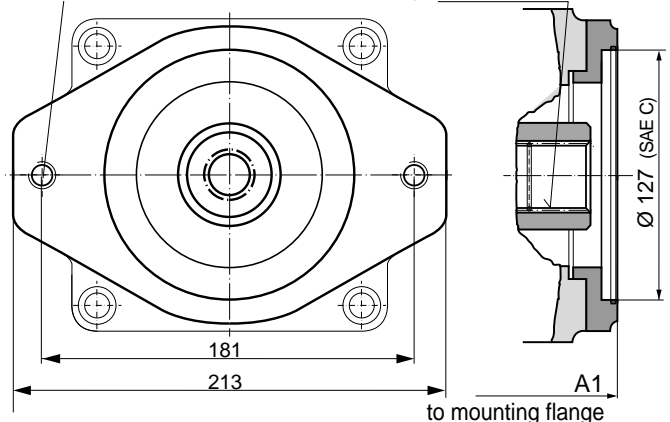

### Total length A1

hub	SAE C K07	SAE C-C K24	N30 K80	N35 K61
size 60			265	265
75			283	283
95	318		318	318
130	330		330	330
130*	364		364	364
190				
190*	400		400	400
260	391,5		391,5	391,5
260*	433,5		433,5	433,5

\*) design with charge pump (impeller)

**Through drive: flange SAE D, hub - SAE C (K86)**

- SAE D (K17)
- N 40 (K81)
- N 45 (K82)
- N 50 (K83)

splined hub SAE C N 1 1/4"-14T 12/24 DP  
 splined hub SAE D N 1 3/4"-13T 8/16 DP  
 splined hub DIN 5480 N 40x2x30x18x9H  
 splined hub DIN 5480 N 45x2x30x21x9H  
 splined hub DIN 5480 N 50x2x30x24x9H

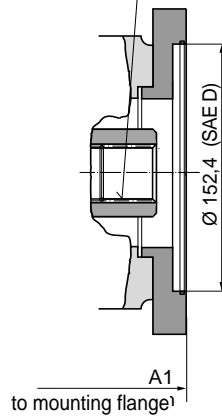
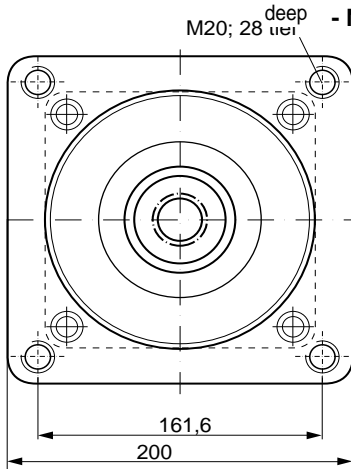

**Total length A1**

hub	SAE C K86	SAE D K17	N 40 K81	N 45 K82	N 50 K83
size 75		—		—	—
95		—		317	—
130	340		340	340	340
130*					
190					
190*					
260					
260*					

\*) design with charge pump (impeller)

**Through drive: flange SAE E, hub - SAE D (K72)**

- N 50 (K84)
- N 60 (K67)

splined hub DIN 5480 N 50x2x30x24x9H  
 splined hub DIN 5480 N 55x2x30x26x9H  
 splined hub DIN 5480 N 60x2x30x28x9H

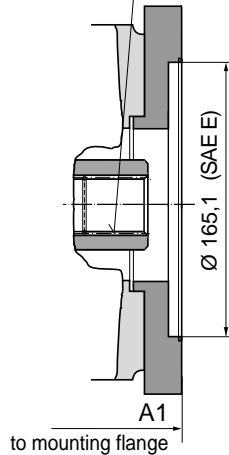
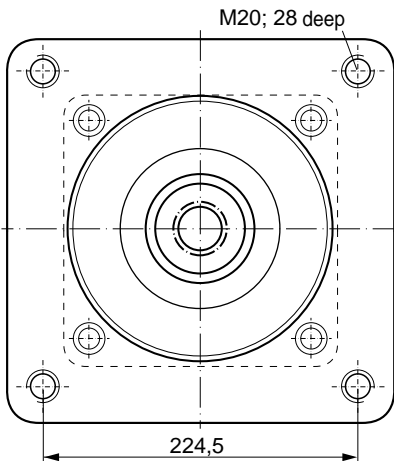

**Total length A1**

hub	SAE D K72	N 50 K84	N 60 K67
size 190			
190*		409	409
260		400	400
260*		442,5	442,5

\*) design with charge pump (impeller)

**Input Drive**

**Permissible axial and radial loading on drive shaft**

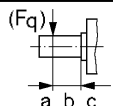
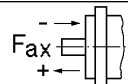
Size				40	60	75	95	130	190	260
distance of $F_q$ (from shaft collar)		a	mm	17,5	17,5	20	20	22,5	26	29
		b	mm	30	30	35	35	40	46	50
		c	mm	42,5	42,5	50	50	57,5	66	71
max. perm. radial load at distance	a	$F_{q \max}$	N	3600	5000	6300	8000	11 000	16 925	22 000
	b	$F_{q \max}$	N	2891	4046	4950	6334	8594	13 225	16 809
	c	$F_{q \max}$	N	2416	3398	4077	5242	7051	10 850	13 600
max. perm. axial load		$\pm F_{ax \max}$	N	1500	2200	2750	3500	4800	6000	4150

## Summary of the Assembly Possibilities for A11VO

Through drive (A11VO)			assembly possibilities (2nd pump)					available for (see page 3):	
hub	flange		A11VO	A10V(S)O	A10VG	A4VG	others		
<b>K01</b>	SAE A	SAE A		SIZE 10,18				G2	A11VO 40...260
<b>K02</b>	SAE B	SAE B		size 28	size 18			G3	A11VO 40...260
<b>K04</b>	SAE B-B	SAE B	size 40	size 45	size 28, 45	size 28			A11VO 40...260
<b>K07</b>	SAE C	SAE C	size 60	size 60, 71		size 40, 56, 71			A11VO 60...260
<b>K86</b>	SAE C	SAE D	size 75						A11VO 75...260
<b>K24</b>	SAE C-C	SAE C		size 100					A11VO 95...260
<b>K17</b>	SAE D	SAE D	size 95, 130	size 140		size 90, 125			A11VO 130...260
<b>K72</b>	SAE D	SAE E	size 190, 260			size 180			A11VO 190...260
<b>K80</b>	N30	SAE C				size 40, 56			A11VO 60...260
<b>K79</b>	N35	SAE B	size 40						A11VO 40...260
<b>K61</b>	N35	SAE C	size 60			size 71			A11VO 60...260
<b>K81</b>	N40	SAE D	size 75			size 125			A11VO 75...260
<b>K82</b>	N45	SAE D	size 95			size 90			A11VO 95...260
<b>K83</b>	N50	SAE D	size 130						A11VO 130...260
<b>K84</b>	N50	SAE E	size 190			size 180			A11VO 190...260
<b>K67</b>	N60	SAE E	size 260						A11VO 260

## Combination Pumps A11VO + A11VO, total length A <sup>1)</sup>

A11VO (1st pump)	A11VO (2nd pump)									
	size 40	size 60	size 75	size 95	size 130	size 130*	size 190	size 190*	size 260	size 260*
size 40	—	—	—	—	—	—	—	—	—	—
size 60	507	—	—	—	—	—	—	—	—	—
size 75	525	—	—	—	—	—	—	—	—	—
size 95	528	560	604	—	—	—	—	—	—	—
size 130	551	572	600	627	650	698	—	—	—	—
size 130*	606	—	—	—	—	—	—	—	—	—
size 190	—	—	—	—	—	—	—	—	—	—
size 190*	619	642	—	—	—	—	803	—	—	—
size 260	620	633	—	—	—	—	794	758	829	—
size 260*	662,5	675,5	—	—	—	—	837	801	871	—

<sup>1)</sup> in case of use of the Z-shaft (splined shaft DIN 5480) for the mounted pump (2nd pump)

\*) design with charge pump (impeller)

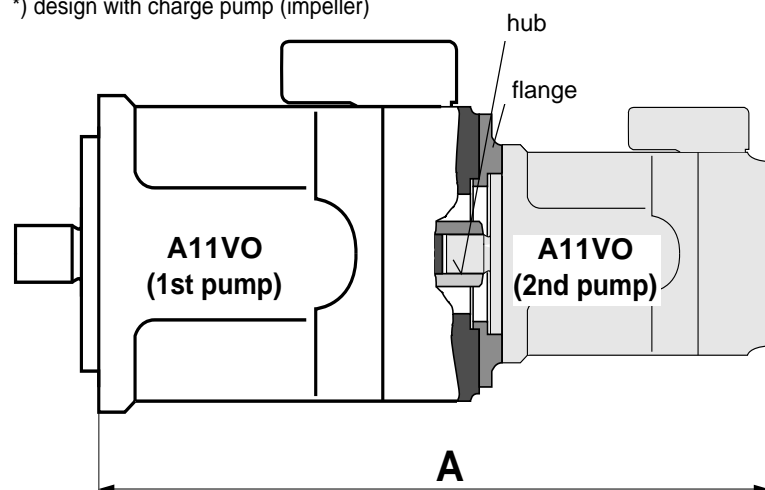

When ordering combination pumps the ordering code have to be connected by a "+" sign.

ordering code 1st pump  
+  
ordering code 2nd pump

A11VO130LRDS/10R-PZD12**K61**  
+  
A11VO60LRDS/10R-PZC12N00

## Permissible Input and Through Drive Rotation Torques

Size			40	60	75	95
Corner torque at $V_{g\max}$ and $\Delta p = 350 \text{ bar}^1$ )	$T_{\max}$	Nm	234	324	412	522
Max. perm. input torque <sup>2)</sup>						
shaft end P (DIN 6885)	$T_{\max}$	Nm	468	648	824	1044
shaft end Z (DIN 5480)	$T_{E\text{ perm.}}$	Nm	912 (W35x2x30x16x9g)	912 (W35x2x30x16x9g)	1460 (W40x2x30x18x9g)	2190 (W45x2x30x21x9g)
shaft end S SAE (ANSI B92.1a-1976)	$T_{E\text{ perm.}}$	Nm	314 (SAE B-B) (W1"-15T 16/32DP)	602 (SAE C) (W1 <sup>1</sup> / <sub>4</sub> "-14T 12/24DP)	602 (SAE C) (W1 <sup>1</sup> / <sub>4</sub> "-14T 12/24DP)	1640 (SAE D) (W1 <sup>3</sup> / <sub>4</sub> "-13T 8/16DP)
shaft end T SAE (ANSI B92.1a-1976)	$T_{E\text{ perm.}}$	Nm	602 (SAE C) (W1 <sup>1</sup> / <sub>4</sub> "-14T 12/24DP)	970 (W1 <sup>3</sup> / <sub>8</sub> "-21T 16/32DP)	970 (W1 <sup>3</sup> / <sub>8</sub> "-21T 16/32DP)	
Max. perm. through drive torque <sup>3)</sup>	$T_{D\text{ perm.}}$	Nm	314	521	660	822

Size			130	190	260	
Corner torque at $V_{g\max}$ and $\Delta p = 350 \text{ bar}^1$ )	$T_{\max}$	Nm		723	1073	1447
Max. perm. input torque <sup>2)</sup>						
shaft end P (DIN 6885)	$T_{\max}$	Nm		1448	2226	2787
shaft end Z (DIN 5480)	$T_{E\text{ perm.}}$	Nm		3140 (W50x2x30x24x9g)	3140 (W50x2x30x24x9g)	5780 (W60x2x30x28x9g)
shaft end S SAE (ANSI B92.1a-1976)	$T_{E\text{ perm.}}$	Nm		1640 (SAE D) (W1 <sup>3</sup> / <sub>4</sub> "-13T 8/16DP)	1640 (SAE D) (W1 <sup>3</sup> / <sub>4</sub> "-13T 8/16DP)	1640 (SAE D) (W1 <sup>3</sup> / <sub>4</sub> "-13T 8/16DP)
shaft end T SAE (ANSI B92.1a-1976)	$T_{E\text{ perm.}}$	Nm			2670 (SAE F) (W2"-15T 8/16DP)	4070 (W2 <sup>1</sup> / <sub>4</sub> "-17T 8/16DP)
Max. perm. through drive torque <sup>3)</sup>	$T_{D\text{ perm.}}$	Nm		1110	1760	2065

1) efficiency not considered

2) for drive shaft without radial load

3) note max. perm. input torque for shaft end **S!**

### Code explanations

$T_{D\text{ perm.}}$  = max permissible through drive torque in Nm

$T_{E\text{ perm.}}$  = max. permissible input torque at the drive shaft in Nm

$T_1$  = take off torque at the 1st pump =  $\frac{1,59 \cdot V_{g1} \cdot \Delta p_1}{100 \cdot \eta_{mh}}$  in Nm

$T_2$  = take off torque at the 2nd pump =  $\frac{1,59 \cdot V_{g2} \cdot \Delta p_2}{100 \cdot \eta_{mh}}$  in Nm

$V_{g1}$  = pump displacement per rev. 1st pump in cm<sup>3</sup>

$V_{g2}$  = pump displacement per rev. 2nd pump in cm<sup>3</sup>

$\Delta p_1$  = differential pressure 1st pump in bar

$\Delta p_2$  = differential pressure 2nd pump in bar

$\eta_{mh}$  = mechanical-hydraulic efficiency

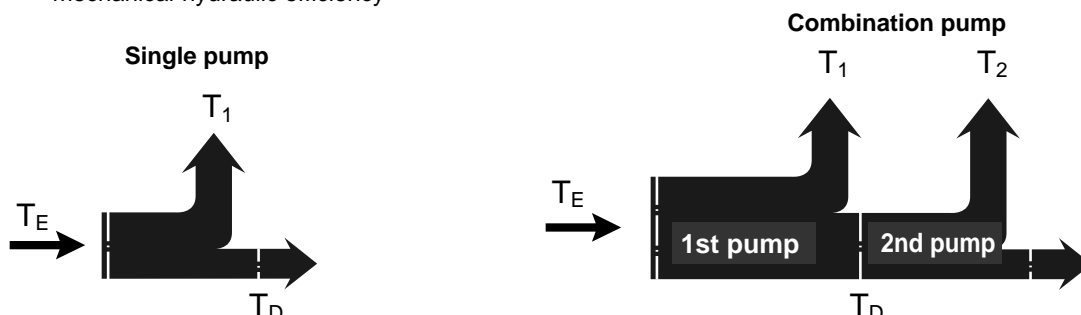

**Preferred Types**, please state type and ident-no. when ordering

Type	Ident-No.	Type	Ident-No.
A11VO40LRS/10R-NSC12N00	9609790	A11VLO190LRS/11R-NSD12N00	2015194
A11VO40LRS/10R-NPC12N00	9609791	A11VLO190LRS/11R-NPD12N00	2015195
A11VO40LRH2/10R-NSC12N00	9609792	A11VLO190LRS/11R-NSD12K02	2015196
A11VO40LRH2/10R-NPC12N00	9609793	A11VLO190LRS/11R-NPD12K02	2015197
A11VO40DRS/10R-NSC12N00	9609656	A11VLO190LRH2/11R-NSD12N00	2015198
A11VO40DRS/10R-NPC12N00	9609794	A11VLO190LRH2/11R-NPD12N00	2015199
		A11VLO190LRH2/11R-NSD12K02	2015250
A11VO60LRS/10R-NSC12N00	9609798	A11VLO190LRH2/11R-NPD12K02	2015251
A11VO60LRS/10R-NPC12N00	9609799	A11VLO190DRS/11R-NSD12N00	2015252
A11VO60LRS/10R-NSC12K01	9609800	A11VLO190DRS/11R-NPD12N00	2015253
A11VO60LRS/10R-NPC12K01	9609801	A11VLO190DRS/11R-NSD12K02	2015254
A11VO60LRH2/10R-NSC12N00	9609802	A11VLO190DRS/11R-NPD12K02	2015255
A11VO60LRH2/10R-NPC12N00	9609803		
A11VO60LRH2/10R-NSC12K01	9609804	A11VLO260LRS/11R-NSD12N00	2015256
A11VO60LRH2/10R-NPC12K01	9609805	A11VLO260LRS/11R-NPD12N00	2015257
A11VO60DRS/10R-NSC12N00	9606644	A11VLO260LRS/11R-NSD12K02	2015258
A11VO60DRS/10R-NPC12N00	9609807	A11VLO260LRS/11R-NPD12K02	2015259
A11VO60DRS/10R-NSC12K01	9601648	A11VLO260LRH2/11R-NSD12N00	2015260
A11VO60DRS/10R-NPC12K01	9609809	A11VLO260LRH2/11R-NPD12N00	2015261
		A11VLO260LRH2/11R-NSD12K02	2015262
A11VO75LRS/10R-NSD12N00	9609815	A11VLO260LRH2/11R-NPD12K02	2015263
A11VO75LRS/10R-NPD12N00	9609816	A11VLO260DRS/11R-NSD12N00	2015264
A11VO75LRS/10R-NSD12K01	9609817	A11VLO260DRS/11R-NPD12N00	2015265
A11VO75LRS/10R-NPD12K01	9609818	A11VLO260DRS/11R-NSD12K02	2015266
A11VO75LRH2/10R-NSD12N00	9609819	A11VLO260DRS/11R-NPD12K02	2015267
A11VO75LRH2/10R-NPD12N00	9609820		
A11VO75LRH2/10R-NSD12K01	9609821		
A11VO75LRH2/10R-NPD12K01	9609822		
A11VO75DRS/10R-NSD12N00	9448021		
A11VO75DRS/10R-NPD12N00	9609824		
A11VO75DRS/10R-NSD12K01	9609825		
A11VO75DRS/10R-NPD12K01	9609826		
A11VO95LRS/10R-NSD12N00	9609834		
A11VO95LRS/10R-NPD12N00	9609835		
A11VO95LRS/10R-NSD12K01	9609836		
A11VO95LRS/10R-NPD12K01	9609837		
A11VO95LRH2/10R-NSD12N00	9609838		
A11VO95LRH2/10R-NPD12N00	9609839		
A11VO95LRH2/10R-NSD12K01	9609840		
A11VO95LRH2/10R-NPD12K01	9609841		
A11VO95DRS/10R-NSD12N00	9609842		
A11VO95DRS/10R-NPD12N00	9608484		
A11VO95DRS/10R-NSD12K01	9609844		
A11VO95DRS/10R-NPD12K01	9609845		
A11VO130LRS/10R-NSD12N00	9609848		
A11VO130LRS/10R-NPD12N00	9609646		
A11VO130LRS/10R-NSD12K02	9609850		
A11VO130LRS/10R-NPD12K02	9609851		
A11VO130LRH2/10R-NSD12N00	9609852		
A11VO130LRH2/10R-NPD12N00	9609853		
A11VO130LRH2/10R-NSD12K02	9609854		
A11VO130LRH2/10R-NPD12K02	9609855		
A11VO130DRS/10R-NSD12N00	9601036		
A11VO130DRS/10R-NPD12N00	9609857		
A11VO130DRS/10R-NSD12K02	9609858		
A11VO130DRS/10R-NPD12K02	9609859		